



RHM 20

Industrial Coriolis Mass Flow Meter

General Flow Control / Plant Balance / Additive Dosing / Mixing and Batching / Package and Container Filling





Features

- Typical measuring range up to 480 kg/min (1058.22 lb/min)
- Pressure ratings up to 400 bar (5801 psi)
- Temperature ratings from -50 to +210 °C (-58 to +410 °F) – extended on request
- Mass flow uncertainty down to 0.05%
- Repeatability down to 0.05 %
- 4 kHz measurement updates and response time of less than 10 ms when used with RHE 40 Series transmitters
- Accurately measure flow rates down to 1 kg/min
- The Rheonik **AnyPipeFit Commitment** provides custom process connection type and size flexibility on any meter to suit your existing plant, saving time and expense on installation costs
- Compact design with minimal pipeline footprint
- Approved for use in hazardous areas
- SS 304 Stainless steel enclosure, SS 316L optional
- Integral and remote transmitter versions available

General Specification Overview

Nominal Flow (Q_{nom})*	360 kg/min (793.66 lb/min)
Maximum Flow (Q_{max})*	480 kg/min (1058.22 lb/min)
Typical Minimum Flow (Q_{min})*	1 kg/min (2.21 lb/min)
Operating Temperature	Fluid temperature range options cover applications from -50°C to 210°C (-58°F to 410°F).
Ambient Temperature	-50 °C to +80 °C (-60 °F to +180 °F). High temperature version for oven installation up to +210 °C (+410 °F) available
Pressure Ratings	Up to 400 bar / 5801 psi - dependent upon material
Electrical Connection Sensor w/o Integral Transmitter	M20 x 1.5 standard cable entry for JM, SM terminal box versions Optional entries available: ½" NPT or M25 x 1.5 (only for SM) or ¾" NPT (only for SM) M16 x 1.5 standard cable entry for PM terminal box version Max. cable length to remote RHE transmitter 100 m/330 ft
Sensor Enclosure Materials	Stainless steel 304 (standard), SS 316L (optional) Coated aluminum terminal box, SS 316L terminal box (optional)
Enclosure Type	Protection class IP66 (IP66 is mostly equivalent to NEMA 4X) Optionally IP66-IP67 (IP67 declared by manufacturer, IP67 is mostly equivalent to NEMA 6)
Wetted Materials	Flow tubes SS 316L or SuperDuplex Manifolds SS 316L; seals: FKM, FFKM, FVMQ Standard flanges SS 316Ti, other connections SS 316L Additional/customer specific materials available upon request
Process Connections	Nearly any – the Rheonik AnyPipeFit Commitment . Consult factory for types/sizes not listed in this data sheet on the Mechanical Construction pages
Pressure Rating Compliance	Pressure Equipment Directive (PED)
Certifications and Approvals	ATEX / IECEx Approvals for Zone 0, 1, 2 (details see page 13) North American Approvals Cl. I, Div. 1, 2, Gr. A,B,C,D, Zone 0, 1, 2 (see page 13) American Bureau of Shipping (ABS) DNV approval for marine applications
Testing and Inspection	All sensors are hydro tested, calibrated and supplied with a traceable calibration certificate. Customized calibration and testing services are available
Project Documentation and QA, Services	Rheonik offers a full set of services for large and complex engineering projects. Typical services offered are, but not limited to: <ul style="list-style-type: none"> • Certificates of origin and conformity, mill certificates • Data books including WPAR, WQS, NDT, test & quality plans, functional testing, calibration procedures, customized packing, factory acceptance etc. • Painting to project specification • Start up and commissioning services on/offshore
Options	Customization services for machine integration. Consult factory

* At Q_{nom} pressure drop across a parallel tube sensor will be approximately 1.3 bar (18.86 psi) for H₂O. Sensors can be operated at higher flow rates up to Q_{max} but pressure drop will be higher. Typical Minimum Flow Q_{min} is the recommended lowest flow rate for an accurate measurement. Sensors will measure flow rates lower than Q_{min} but uncertainty will increase beyond 1% of rate.

The flow rate specifications above relate to standard pressure, parallel tube, manifold sensor versions. Models with higher pressure ratings have increased wall thickness and will have higher pressure drops.

Calibration Options

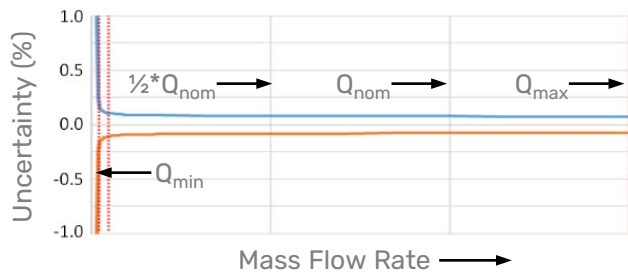

Order Code	General Accuracy Calibration
A	Standard - 0.20 % Uncertainty
B	Premium - 0.15 % Uncertainty

Order Code	High Accuracy Calibration
G	Premium Plus - 0.10 % Uncertainty
U	Ultimate - 0.05 % Uncertainty <i>Requires RHE 40 Series transmitter</i>

Order Code	Focused Calibration
1	0.10 % Low Flow Calibration* <i>Requires RHE 40 Series transmitter</i>
X	Customized Calibration** Consult factory

* Low flow calibration focuses on the range from $\frac{1}{2}Q_{nom}$ downwards to lower flow rates than on other calibrations. Often used for low pressure gas or very viscous liquids

** Customized calibration uses specific calibration points according to customer requirements

Reference conditions:

- 18–24°C Water @ 1–3 bar

Order Code	Density Calibration / Performance (Liquid)
N	No Density Calibration
S	Standard ± 0.001 kg/l Uncertainty
D	Enhanced ± 0.0005 kg/l Uncertainty Requires High Accuracy or Focused Calibration Option

Uncertainties and flow measurement turn-down

The turn down capability from Q_{nom} of the flow sensor is driven mainly by its zero point stability. At the very low end of the measuring range the uncertainty (u) is dominated by zero point stability.

- Zero point stability of a standard sensor with General Accuracy Calibration is: 0.03 kg/min (0.06614 lbs/min).
- Zero point stability of a Gold Line sensor with High Accuracy or Focused Calibration is 0.015 kg/min (0.03307 lbs/min).
- For flow $Q \geq ZP \text{ stability} / (\text{Base Calibration uncertainty}/100) \rightarrow u = \text{calibration uncertainty}$
- For flow $Q < ZP \text{ stability} / (\text{Base Calibration uncertainty}/100) \rightarrow u = (\text{zero stability}/Q) * 100$

Uncertainties from environmental and process conditions

If sensors are not zeroed at operating conditions, minor additional uncertainties can arise from elevated temperatures and pressures:

- ± 0.00022 % of maximum flow per °C
- ± 0.0005 % of maximum flow per bar.

Process temperature effect on density:

- Additional uncertainty of ± 0.000071 g/cm³ per °C difference from calibration temperature with standard density calibration
- Additional uncertainty of ± 0.000009 g/cm³ per °C difference from calibration temperature with enhanced density calibration.
- This effect can be mitigated by a simple field density adjustment at operating conditions.

Process pressure effect on mass flow:

The effect of pressure on flow measurement is 0.0001 % of rate per bar. Compensation is possible by pressure sensor input (analog input or digital write) or manual value entry into the transmitter.

Process pressure effect on density:

- The effect of pressure on density measurement is 0.000075 g/cm³ per bar. Compensation is possible by pressure sensor input (analog input or digital write) or manual value entry into the transmitter.

Premium Plus, Ultimate, Low Flow and Enhanced Density Calibration are only available in SS316 material, P1 lower pressure and N1 temperature range.

Applying Premium Plus calibration to higher pressure, special materials and/or non-standard temperature models will show higher zero uncertainties (up to 3 times higher than standard sensor).

Flow Measurement Repeatability

Sensors with General Accuracy Calibration ± 0.1 % of rate

Sensors with High Accuracy/Focused Calibration ± 0.05 % of rate

Temperature Measurement

Better than ± 1 °C

Pressure Drop

Every Coriolis flow sensor generates pressure drop across its inlet and outlet when in use. The amount of pressure drop generated is mainly a function of the flow velocity within its tubes and the flowing viscosity of the stream.

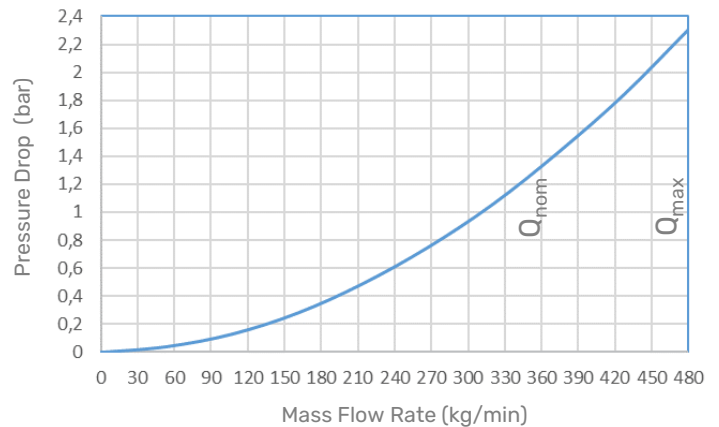

0 – 480 kg/min water, sensor with P1 pressure rating. Higher viscosities create higher pressure drop

Measurement Tube Materials and Pressure Ratings

The maximum pressure (p_{max}) of a sensor is determined by its lowest rated part. The lowest rated part can be either the measurement tube (p_{max} see table to the right), the connection block/manifold (p_{max} indicated in the mechanical construction section) or the process connection (for p_{max} see published standards or manufacturer information).

Note:

The material of the connection block/manifold is always SS 316L.

The material of the process connection of sealless versions is usually the same as the measurement loops however could be different in special cases on PFT.

Order Code	Material	50°C / 122°F	120°C / 248°F	210°C / 410°F
P1	SS 316L (standard)	139 2016	123 1783	104 1508
P2	Super Duplex*	809 11733	709 10283	641 9296

* Note minimum operating temperature for SuperDuplex stainless steel is -40 °C Units: bar / psi

Other Materials

Other wetted materials may be possible for chemical compatibility, lower pressure drop, abrasion allowance, other application specific requirements. Rheonik can provide nearly any material for the wetted parts. Contact factory with specification for assessment and availability.

Mechanical Construction

Sensors are manufactured with two internal measurement tubes arranged side by side. In parallel or dual measurement path sensors (order code Pxx), these tubes are connected in parallel, and the flowing fluid is split equally between them. In serial or single measurement path sensors (order code Sxx), the internal tubes are connected end to end, creating a single path through which all fluid flows. Manifold designs have a removable inlet/outlet block/manifold and utilize seals between the manifold and sensor body. In sealless designs, the measurement tubes are continuous between the process connections and do not have seals. Manifold designs typically offer shorter delivery lead times and may have a lower pressure drop than sealless designs for the same flow rate.

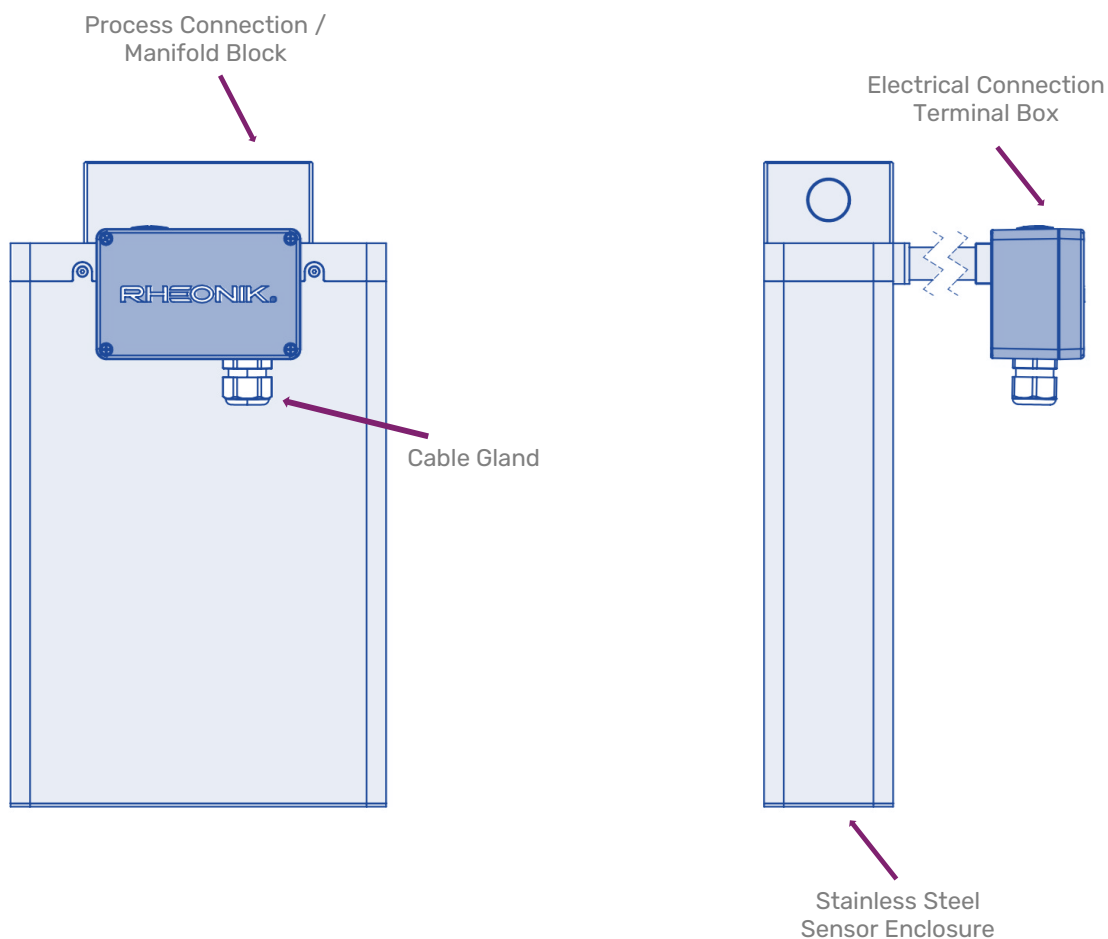

Note

All dimensions in the following pages are for standard design products. For customization of face to face length and/or process connection types other than the ones listed on the following page, please consult factory. Note that larger diameter flange process connections are always possible. The tolerance of the process connections is ± 2 mm.

Manifold design with threaded process connections

Parallel tube / dual measurement path

Order Code: PMO

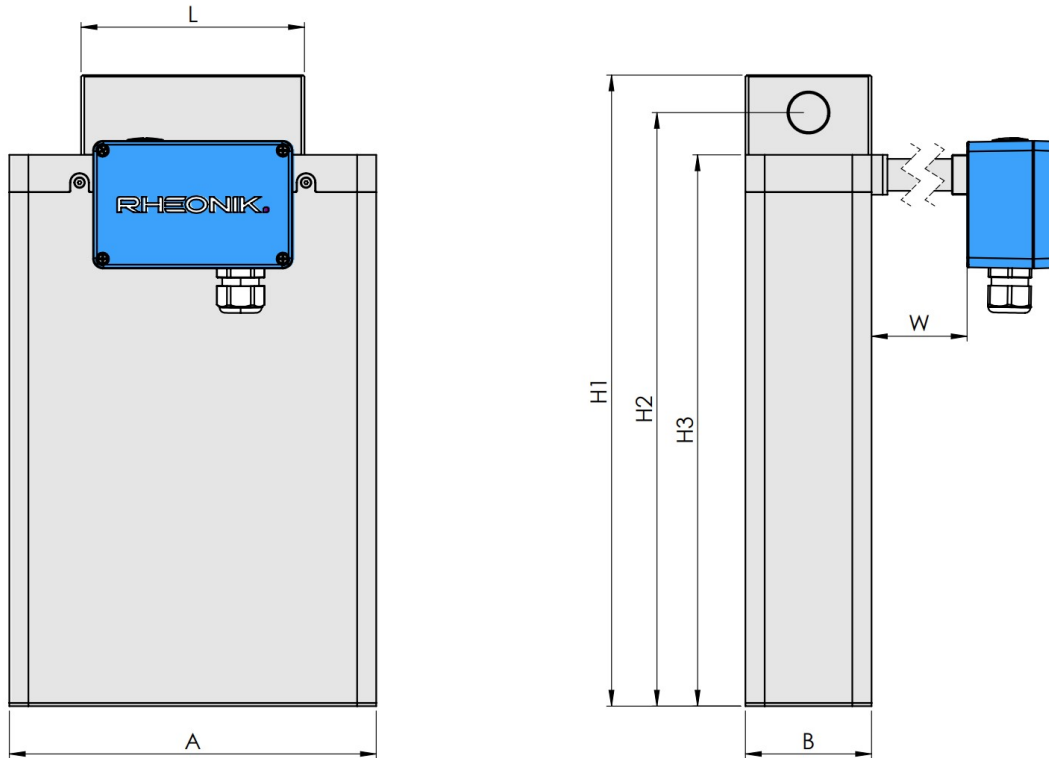

PMO Process Connection	Dim. L mm / in	Order Code
Female Thread G 1"	140 / 5.51	G1
Female Thread 1" NPT	140 / 5.51	N1

PMO Dimensions	mm	in
A	270	10.63
B	79	3.11
H1	445	17.52
H2	417	16.42
H3	385	15.16
W	see page 9	see page 9

Manifold Pressure Ratings @ 120 °C / 248 °F

PMO – 400 bar / 5801 psi

Weights and Shipping Dimensions

- Weight for sensor with threads: ~19.5 kg/43 lb
- Shipping carton size ~49 x 40 x 27 cm (20 x 16 x 11 in)
- Gross weight with RHE 28, packaging: ~24 kg/53 lb

Material of Manifold and Seals (Wetted Part)

The connection block/manifold is made of SS316L. Depending upon sensor temperature range, sensors are supplied with the following seal types as standard. For alternative seal options (e.g., FFKM seals for N1) please see Options Codes on page 12. Other seals on request.

Temperature Range	PMO
N1	FKM
NA	FVMQ
E2	FFKM*

*FFKM seals minimum temperature is -20 °C/-4 °F

Manifold design with flanged process connections

Parallel tube / dual measurement path

Order Code: PMO

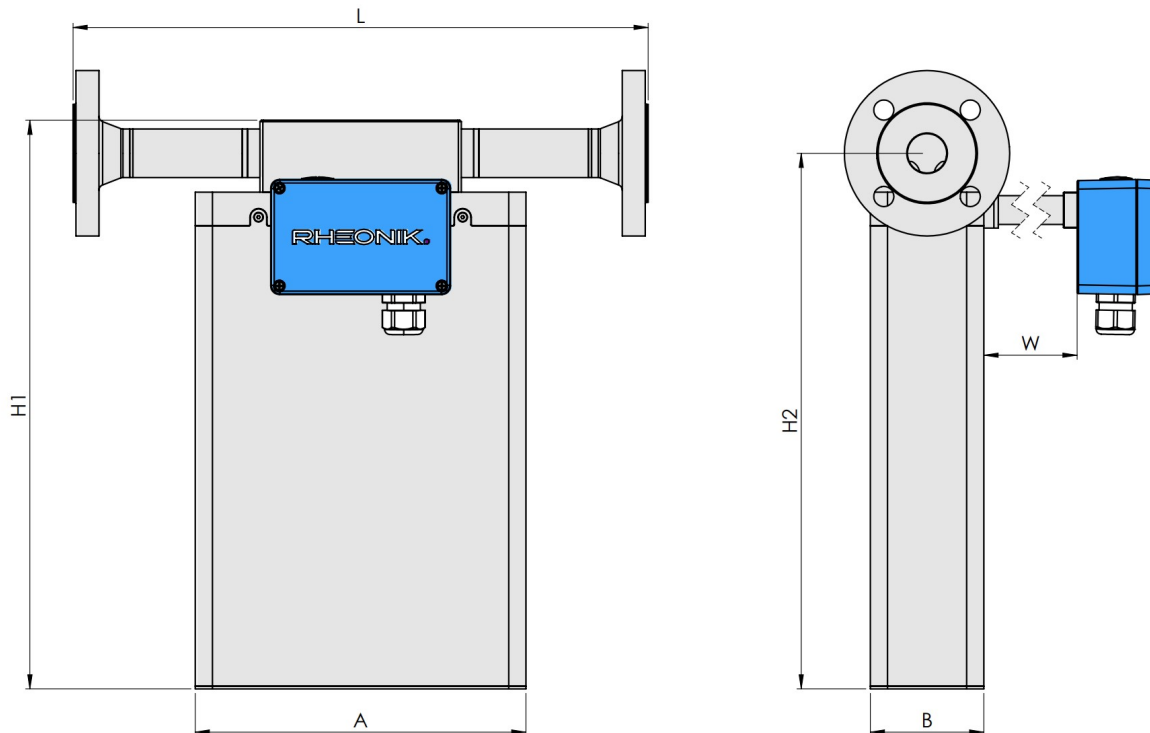

PMO Process Connection	Dim. L mm / in	Order Code
ANSI 1½" 150#RF	460 / 18.11	A1
ANSI 1½" 300#RF	460 / 18.11	A2
ANSI 1½" 600#RF	460 / 18.11	A3
DIN DN40/PN40 Form B1	460 / 18.11	D1
DIN DN40/PN100 Form B2	460 / 18.11	D2
Flange JIS B 2220 RF 10k 40A (1½")	460 / 18.11	J1
Flange JIS B 2220 RF 20k 40A (1½")	460 / 18.11	J2

Manifold Pressure Ratings @ 120 °C / 248 °F

PMO – 400 bar / 5801 psi

Weights and Shipping Dimensions

- Approx. weight with 1.5" 150# flanges: ~ 23.5 kg / 51.8 lb
- Shipping carton size: ~70 x 50 x 50 cm (28 x 20 x 20 in)
- Gross weight with RHE28, packing: ~28 kg / 61.7 lb

PMO Dimensions	mm	in
A	270	10.63
B	79	3.11
H1	445	17.52
H2	417	16.42
W	see page 9	see page 9

Material of Manifold and Seals (Wetted Part)

The connection block/manifold is made of SS316L. Depending upon sensor temperature range, sensors are supplied with the following seal types as standard. For alternative seal options (e.g., FFKM seals for N1) please see Options Codes on page 12. Other seals on request.

Temperature Range	PMO
N1	FKM
NA	FVMQ
E2	FFKM*

*FFKM seals minimum temperature is -20 °C/-4 °F

Electrical Connection Options To Transmitters

Any Rheonik Mass Flow Transmitter model can be combined with any Rheonik Mass Flow Sensor to provide an overall mass flow measurement system to suit any requirement. Rheonik Coriolis transmitters are available in both integral and remote mounting styles. A range of connection options is available to suit all application requirements

Order Code: JM
Standard Coated Aluminum Terminal Box

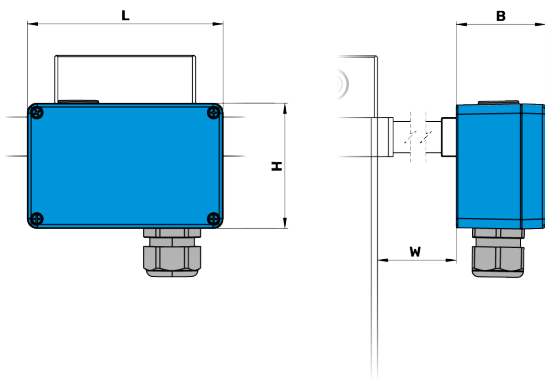

Order Code: PM
Compact Coated Aluminum Terminal Box

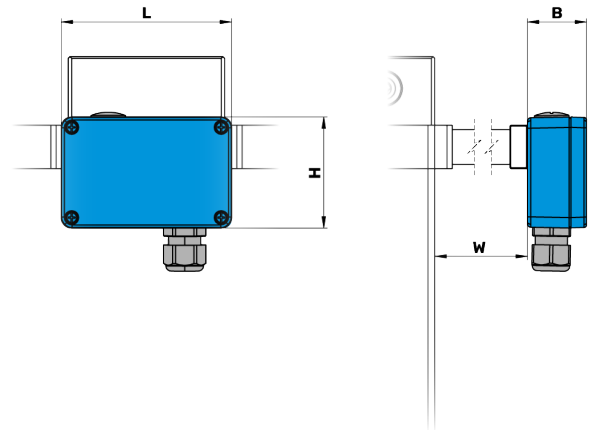

Order Code: SM
Terminal Box and Entire Enclosure in SS 316

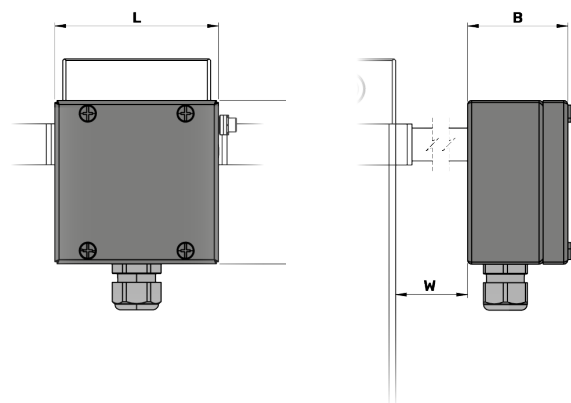

Order Code: TM
Integral PTFE Cable (No Terminal Box). Std. Length 2 m. Can be extended up to max 10 m

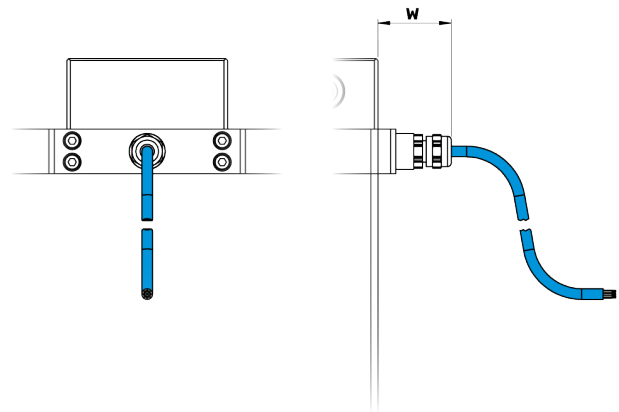

Connection Option	Dimension	mm	in
JM Terminal Box	L x H x B	125 x 80 x 57	4.92 x 3.15 x 2.24
PM Compact Terminal Box	L x H x B	98 x 64 x 34	3.86 x 2.52 x 1.34
SM SS316 Terminal Box	L x H x B	100 x 100 x 61	3.94 x 3.94 x 2.40
TM Integral PTFE Cable	W	41	1.61
JM, PM, SM with Temperature Range N1, NA	W	2	0.08
JM, PM, SM with Temperature Range E2, E3	W	100	3.94

JM, SM Terminal boxes are supplied with an M20 x 1.5 cable entry, optional entries available – see Separately Ordered Options, page 12
PM Compact Terminal boxes are supplied with an M16 x 1.5 cable entry
For details of the integral transmitter used with option J5, J9 and S9 please see the RHE45 or RHE49 datasheet

Electrical Connection to Transmitter Compatibility

Electrical connection option selections are compatible with the transmitter range according to the following table. Note that economical blind front versions of some transmitters are available where displays and keypads are not required. The wide range of Rheonik sensors and transmitters provide tremendous options for system designers and end users alike.

Sensor Connection Options	Order Code	   					
		JM	SM	S9	TM	J5	J9
	RHE 21	✓	✓	—	✓	—	—
	RHE 26	✓	✓	—	✓	—	—
	RHE 27	✓	✓	—	✓	—	—
	RHE 28	✓	✓	—	✓	—	—
	RHE 42	✓	✓	—	✓	—	—
	RHE 45	—	—	—	—	✓	—
	RHE 46	✓	✓	—	✓	—	—
	RHE 49	—	—	✓	—	—	✓

RHM 20 Part Number Code

Temperature Range

- N1 -20 to +120°C (-4 to +248°F)
- NA -50 to +120°C (-58 to +248°F)
- E2 -50 to +210°C (-58 to +410°F)
- E3 -196 to +50°C (-320 to +122°F) - only sealless

Pressure Range of Measurement Loops @ 120°C / 248°F

See pressure ratings page for ratings and codes

Construction Type - p_{max} indications refer to 120°C / 248°F

- PMO Parallel block/manifold in SS316L with seals, p_{max} = 400 bar
- PFO Parallel Tube, sealless - only with flange / hub connections
- PFT Parallel Tube, sealless - only with thread connections

Material of Measuring Loops

- 04 SS316L / EN 1.4404 / UNS S31603
- 10 SuperDuplex / EN 1.4410 / UNS S32750
- M3 Alloy C22 / EN 2.4602 / UNS N06022 - only sealless

Process Connection

See mechanical construction pages for available connections and codes

Electrical Connection to Transmitter

- JM Terminal Box coated Aluminum - M20 x 1.5 cable entry, see Accessories for others - not with Haz. Area A0
- J5 Alu Box ready for integrated RHE45 - temperature restrictions apply - only Haz. Area NN
- J9 Alu Box ready for integrated RHE49 - temperature restrictions apply
- SM Terminal Box and entire Enclosure/Housing in SS316 - M20x1.5 cable entry, see Accessories for others
- S9 SS316 Box ready for integrated RHE49 and entire Enclosure/Housing in SS316 - temperature restrictions apply
- TM Integral PTFE Cable to RHE, 2m - not with H4, A0. C0 only with N1, NA

Options Codes

See options listing for specific codes

Hazardous Area Certifications (details see page 13)

- NN Without Ex Approval
- A2 ATEX/IECEx Approvals Zone 2
- A1 ATEX/IECEx Approvals Zone 1 - requires suitably rated RHE
- A0 ATEX/IECEx Approvals Zone 0 - requires Elec. Conn. SM, suitably rated RHE
- C2 CSA Approval US-Canada Class I, Zone 2, Gas IIC
- C0 CSA Approval US-Canada Class I, Div. 1, Groups A,B,C,D / Zone 0, Gas IIC - requires suitably rated RHE

Pressure Design Compliance

- NN Rheonik standard design based on EN codes (no PED - not for sales into EU)
- PE Conformity according to the Pressure Equipment Directive (PED)

Performance Certification

- NN No Performance Certification
- AB ABS approval for marine applications - includes approval for RHE Transmitter
- DV DNV approval for marine applications – requires RHE42/45, only for RHM with flange connection

Mass Flow, Density Calibration Selection

See calibration options on page 4

Manufacturing Instruction Codes

See instructions listing for specific codes (next page)

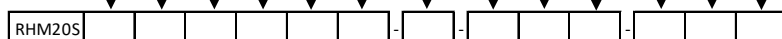

Options Codes

Order Code	
NN	No options selected
T1	Terminal box with cable entry upwards/gas installation
T0	Set-off terminal box for N1, NA temperature range (included in E2, E3)
FO	FVMQ seals for manifolds instead of standard seals - <i>recommended for frequent use < 0 °C</i>
FK	FFKM* seals for manifolds instead of standard seals - <i>high chemical resistance</i>

*FFKM seals minimum temperature is -20°C / -4°F

List multiple options in the sensor part number in the same order as the above list

Manufacturing Instructions

Order Code	
N	No additional manufacturing instructions
F	Drying of sensor internals after calibration with compressed air
7	Upgrade to dual rating IP66/67 - <i>only available with electrical connection SM</i>
O	Special Cleaning, water and oil/grease free
S	Sea-worthy packing

List multiple options in the sensor part number in the same order as the above list

Options

Order Code ORHM-...	
E1	Terminal box cable entry adapted to ½" NPT
E2	Terminal box cable entry adapted to M25 x 1.5 (<i>only with electrical connection SM</i>)
E3	Terminal box cable entry adapted to ¾" NPT (<i>only with electrical connection SM</i>)
E5	Terminal box prepared for M20 x 1.5 cable gland in SS316 (<i>only with electrical connection SM</i>)
E6	Terminal box prepared for ½" NPT cable entry in SS316 (<i>only with electrical connection SM</i>)
TP	Separate stainless steel TAG plate (<i>TAG Information only</i>)
TC	Stainless steel type label (<i>includes TAG and all other sensor information</i>)

Standard cable entry on JM, SM terminal box is M20 x 1.5. Cable entry on PM terminal box is always M16 x 1.5

Hazardous Area Certifications

Order Code	Zone / Division	Approval	Labeling
A2	Zone 2	ATEX IECEX	⊕ Ex II 3G Ex ec IIC T6...T1 Gc Ex ec IIC T6...T1 Gc
A1	Zone 1	ATEX IECEX	⊕ Ex II 2G Ex ib IIC T6...T1 Gb Ex ib IIC T6...T1 Gb
A0	Zone 0	ATEX IECEX	⊕ Ex II 1G Ex ia IIC T6...T1 Ga Ex ia IIC T6...T1 Ga
C2	Zone 2	USA/Canada	Class I, Zone 2, AEx nA IIC T6...T1 Gc
C0	Div 1, Zone 0	USA/Canada	Class I, Div 1, Groups A, B, C and D T6...T1; Class I, Zone 0, AEx ia IIC T6...T1 Ga



About Rheonik

Rheonik has but one single purpose: to design and manufacture the very best Coriolis meters available.

Our research and engineering resources are dedicated to finding new and better ways to provide cost effective accurate mass flow solutions that provide value to our customers. Our manufacturing group care for each and every meter we produce from raw materials all the way to shipping, and our service and support group are available to help you specify, integrate, start-up and maintain every Rheonik meter you have in service. Whether you own just one meter or have hundreds, you will never be just another customer to us. You are our valued business partner.

Need a specific configuration for your plant? Don't compromise with a "standard" product from elsewhere that will add extra cost to your installation. If we can't configure it from our extensive and versatile product range, our exclusive **AnyPipeFit Commitment** can have your flow sensor customized with any size/type of process connection and face to face dimension you need.

No matter what control system you use as the backbone in your enterprise, with our **AnyInterface Commitment**, you can be sure that connection and communication will not be a problem. Alongside a wide variety of discrete analog and digital signal connections, we can also provide just about any network/bus interface available (for example: HART, ProfibusDP, ProfiNet, EtherCAT, PowerLink, EtherNet/IP, CAN,) with our RHE 40 Series family of transmitters. Rheonik RHE 40 Series transmitters can connect to your system – no headache and no conversion needed.

Rheonik Messtechnik GmbH
Rudolf-Diesel-Straße 5
D-85235 Odelzhausen
Germany

Tel + 49 (0)8134 9341-0
Info@rheonik.com

