



Coriolis Mass Flow Sensors RHM 30 – RHM 160

IMPORTANT

Read carefully before use.
Keep for future reference.
If you sell the product, include
this document.

Operation Manual

V02.00

Translated document in English language

X.X.9

15.6.2026



Legal notice

Authorized representative for the compilation of technical documentation:

Rheonik Messtechnik GmbH

Rudolf-Diesel-Str. 5

85235 Odelzhausen

Germany

Tel. + 49 (0)8134 9341-0

info@rheonik.com

<https://www.rheonik.com/>

© Rheonik Messtechnik GmbH 2026

IMPORTANT

Read carefully before use.

Keep this for future reference.

If you sell the product, include this document.

Table of Contents

1	Introduction.....	9
1.1	Glossary.....	9
1.2	Important notes about this document.....	9
1.2.1	Purpose of the document.....	9
1.2.2	Target audiences.....	10
1.2.3	Structure of the documentation.....	11
1.2.4	Presentation conventions.....	11
1.2.4.1	Actions in a specified order.....	11
1.2.4.2	Actions without a specified order.....	11
1.2.4.3	Warning messages.....	12
1.2.4.4	Safety signs.....	13
1.2.4.5	Important information.....	13
1.2.4.6	Quotes.....	13
1.2.4.7	Placeholder in the order code.....	13
1.2.5	Storage.....	13
2	Product description.....	15
2.1	Order code.....	15
2.2	Scope of delivery.....	19
2.3	Condition as delivered.....	19
2.3.1	Inspection upon delivery.....	19
2.4	Important information about the product.....	20
2.4.1	Compliance.....	20
2.4.2	Product labeling.....	21
2.5	Technical specifications.....	22
2.5.1	Features.....	22
2.5.2	Dimensions and weights.....	22
2.5.2.1	Net weights.....	22
2.5.2.2	Shipment dimensions and gross weights.....	22
2.5.2.3	Installation dimensions.....	23
2.5.3	Environmental conditions.....	23
2.5.4	Emissions.....	24
3	Safety.....	25
3.1	Disclaimer.....	25
3.2	Intended use.....	25
3.3	Improper use.....	26
3.4	Personnel qualification.....	26
3.5	Safety instructions.....	27
3.5.1	Protective devices and safety measures.....	27
3.5.2	Operating limits.....	28
3.5.3	Material durability and wear.....	28
3.5.4	Explosion protection.....	28
3.5.4.1	System for use in hazardous areas.....	28
3.5.4.2	Installation in a hazardous area.....	29
3.5.4.3	Additional information for devices with CSA certification.....	30

3.6	Minimum clearances.....	30
3.7	Safety signs.....	31
3.8	Safety-related emissions.....	31
4	Design and function.....	33
5	Transport and installation.....	35
5.1	Safety.....	35
5.2	Packaging and transportation.....	35
5.2.1	Removing the product from the packaging.....	36
5.2.1.1	Carton.....	36
5.2.1.2	Transport crate.....	36
5.2.2	Transport.....	37
5.2.2.1	Lifting points.....	37
5.2.2.2	Transport locks.....	39
5.3	Installation.....	40
5.3.1	Best practices.....	40
5.3.2	Installation orientation.....	42
5.3.2.1	Alignment of process connections.....	43
5.3.2.2	Two-phase mixture.....	44
5.3.2.3	Shut-off valves for zero-point calibration.....	45
5.3.3	Installation position.....	46
5.3.3.1	Recommended installation positions.....	46
5.3.3.2	Critical installation positions.....	47
5.3.3.3	Downpipe.....	48
5.3.3.4	Cavitation, outgassing, evaporation.....	49
5.3.3.5	Out of plane.....	50
5.3.4	Vibrations.....	51
5.3.5	Supports.....	52
5.3.5.1	Supports on pipes.....	52
5.3.5.2	Custody transfer.....	53
5.3.6	Insulation.....	54
5.3.7	IP protection rating.....	54
5.3.8	Electrical connection, grounding.....	55
5.3.8.1	Cable glands in hazardous areas.....	55
5.3.8.2	Grounding.....	56
5.3.8.3	Electrical connection.....	58
5.4	Commissioning.....	59
6	Troubleshooting.....	61
6.1	Troubleshooting.....	63
6.2	Voltage test, resistance test.....	67
7	Maintenance, Inspection.....	69
7.1	Zero-point calibration.....	69
7.2	Options: zero-point history, check zero-point drift, assurance factor.....	69
7.3	Calibration.....	69
7.4	Configuration file.....	70
8	Decommissioning, storage, recommissioning, disposal.....	71

8.1	Decommissioning, Dismantling.....	71
8.2	Storage conditions.....	71
8.3	Restart.....	71
8.4	Disposal.....	71
8.4.1	WEEE, RoHS.....	71
	Appendix.....	73
A	Explosion protection.....	75
A.1	Electrical safety limits for RHM sensors.....	75
A.2	Thermal safety limits for RHM sensors.....	76
A.2.1	Temperature ranges Nx.....	76
A.2.2	Temperature ranges N1, NA with RHE 49, front mounting.....	76
A.2.3	Temperature ranges Ex.....	77
A.2.4	Temperature range E2 with RHE 42.....	78
A.2.5	Temperature range E2 with RHE 49, set-off mounting.....	79
A.2.6	Temperature ranges N1, NA, and E2 with RHE 49, top mounting.....	79
A.2.7	Temperature ranges Hx.....	80
B	Wiring diagrams.....	81
B.1	Connection RHM Sx, Jx to RHE.....	83
B.2	Connection RHM TX to RHE.....	85
C	Terminal resistances, voltages.....	87
	List of Figures.....	89

1 Introduction

1.1 Glossary

Units

Measurement parameter	Unit	Abbreviation/Symbol
Temperature	Degrees Celsius	°C
Pressure	Bar absolute	bara
	Bar gauge pressure	barg
Time	Second	s

Terms

Naming	Explanation
Fluid	Umbrella term for gases, liquids, and flowable multiphase mixtures.

1.2 Important notes about this document

1.2.1 Purpose of the document

This manual is part of the product documentation for your Rheonik measurement system. A Rheonik measurement system always consists of a RHM sensor and a RHE transmitter connected to the sensor. Depending on the scope of delivery, the product documentation consists of the following documents:

- This manual for the RHM sensor.
- A manual for the RHE transmitter.
- Optionally, a declaration of conformity.
- Optional supplementary documents: Addenda, drawings, schematics.

Manuals for sensors and transmitters, as well as additional documents, are available for download on the Rheonik website:

www.rheonik.com

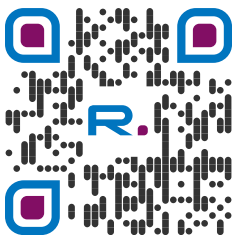

The purpose of this manual is to provide the following information to ensure the safe and efficient use of the sensor by adequately qualified and trained personnel:

- Information on intended use.
- Information regarding activities involving the product.
- Safety information regarding the use of this product.

The document covers the product lifecycle from delivery to disposal.

If you have any questions regarding the setup, operation, or support of your measurement system that are not covered in the included documentation, please contact your local sales/support representative or our Rheonik support team.

1.2.2 Target audiences

This document is intended for all individuals involved in or working with the product throughout its lifecycle, from delivery to disposal.

Operator

This includes the individuals on the customer's side who are responsible for organizing safe operations, ensuring compliance with legal and operational regulations, and for assigning and supervising personnel involved with the product.

Personnel hired by the operator

This target group includes all individuals who work on or with the product. This document is organized according to the tasks associated with each stage of life:

life stage	Target audience	Requirement
Transport	Logistics personnel	Safe movement, lifting, and positioning.
Installation & Commissioning	Installers, Commissioning Technicians	Professional installation, connection, and commissioning.
Operation	Plant supervisor, operator	Proper operation, monitoring, and adjustment procedures.
Maintenance, Inspection	Service personnel	Performing maintenance and inspections
Troubleshooting & Repair	Service personnel	Systematic analysis of malfunctions and troubleshooting.
Decommissioning, Dismantling	Installers, Commissioning Technicians	Safe decommissioning and dismantling.
Disposal	Waste management officer	Dispose of in accordance with local regulations.
Storage	Warehouse workers	Proper short-term or long-term storage.

1.2.3 Structure of the documentation

The documentation for a Rheonik measurement system consists of this Operation Manual and supplementary documents:

- RHE Transmitter manual
- Declaration of conformity

1.2.4 Presentation conventions

1.2.4.1 Actions in a specified order

 **Context**
Instructions explain the prerequisites, the steps to be taken, and the expected results of a procedure to be performed on or with the product.

 **Required support equipment**
✓ Conditions for performing an action.

 **Proceeding**
1. Step
→ Interim result of a step.
2. Next step
→ Interim result of a step.
→ Result of the action.

1.2.4.2 Actions without a specified order

➤ A single step or a series of steps with no specified order.

1.2.4.3 Warning messages

Warning messages draw attention to hazardous situations that may arise when working on or with the product. Signal words and the colors of warning messages are graded according to the severity of the hazard:

DANGER

Signal word used to indicate an immediately dangerous situation that, if not avoided, will result in serious injury or death.

⚠ DANGER



Type of hazard

Possible consequences if the hazard is not avoided

- Appropriate measures to avoid the hazard.

WARNING

Signal word used to indicate a potentially dangerous situation that, if not avoided, could result in death or serious injury.

⚠ WARNING



Type of hazard

Possible consequences if the hazard is not avoided

- Appropriate measures to avoid the hazard.

CAUTION

Signal word used to indicate a potentially hazardous situation that, if not avoided, could result in minor or moderate injury.

⚠ CAUTION



Type of hazard

Possible consequences if the hazard is not avoided

- Appropriate measures to avoid the hazard.

NOTE

Signal word used to indicate a situation that, if not avoided, could result in damage to or destruction of the product.

NOTICE

Type of potential property damage

- Appropriate measures to prevent property damage.

Embedded warning message

In instructions, brief warning messages may be included in the body of the text:

⚠ WARNING! Type of hazard. Action.

1.2.4.4 Safety signs

Depending on the nature of the hazard, a warning message may include a safety sign that more accurately represents the specific hazard instead of the general safety sign.

You can find an overview of the safety signs affixed to the product in [3.7 Safety signs](#), p. 31.

1.2.4.5 Important information

 **Important**

Additional important information is highlighted in this format

1.2.4.6 Quotes

Screenshots and quotes from labels on the equipment are set **bold**.

1.2.4.7 Placeholder in the order code

If statements apply to multiple variants, they are represented by the placeholder "x".

Examples:

Jx includes JM, J2, J5, J9

Ex includes EM, E2, E3, and E4

Refer to chapter [2.1 Order code](#), p. 15.

1.2.5 Storage

The operator must retain the Operation Manual throughout the product's entire life cycle. Users must be able to access the Operation Manual at all times. When the product is sold, the Operation Manual must be included.

2 Product description

A Rheonik measurement system always consists of a RHM sensor and a RHE transmitter connected to the sensor. This document describes the RHM sensor.

Also refer to the RHE transmitter's documentation.

2.1 Order code

Not all combinations are possible. Please refer to the product configurator at <http://www.rheonik.com/>. If you have any questions or need clarification, please contact Sales.

For special versions, different order codes may apply.

"x" is used as a placeholder.

Mxxx ¹	1	2	3	4	5	6	7	8	9	10	11	12	13	14	15
-------------------	---	---	---	---	---	---	---	---	---	----	----	----	----	----	----

¹ xxx = RHM size from 015 to 100

Example: M#10 S - N1 P1 - PM N NN - D01 JM - A1 B1 P NN - A S - NN

1	Performance class	
S	Classic multi purpose high accuracy coriolis mass flowmeter	
P	Premium highest accuracy coriolis mass flowmeter	
2	Temperature range	
N1	Standard temperature range	-20 to +120 °C / -4 to +248 °F
NA	Standard temperature range	-50 to +120 °C / -58 to +248 °F
EM	Extended temperature range	-20 to +160 °C / -4 to +320 °F
E2	Extended temperature range	-50 to +210 °C / -58 to +410 °F
E3	Extended temperature range	-196 to +50 °C / -320 to +122 °F
H4	Extended temperature range	-20 to +350 °C / -4 to +662 °F
3	Material of wetted parts / Pressure range of measurement tube	
Px	316L/Ti stainless steel, pressure as specified in the data sheet/nameplate	
Mx	316L/Ti stainless steel, pressure as specified in the data sheet/nameplate	
Hx	Alloy C22, pressure as specified in the data sheet/nameplate	
Dx	Super Duplex steel, pressure as specified in the data sheet/nameplate	
Vx	Sandvik HP160, pressure as specified in the data sheet/nameplate	
4	Design type	
PM	316L stainless steel parallel connection block with seals	
SM	316L stainless steel serial connection block with seals	
PH	Parallel high-pressure connection block made of 316L stainless steel with seals	

4	Design type
SH	316L stainless steel serial high-pressure connection block with seals
PF	Parallel measurement tube configuration, sealless, flanged connection
PT	Parallel measurement tube configuration, sealless, threaded connection
SF	Serial measurement tube assembly, sealless, flanged connection
ST	Serial measurement tube assembly, sealless, threaded connection
H2	Parallel measurement tube configuration, sealless, for hydrogen applications
5	Wetted seals
0	Sealless
N	FKM
F	FFKM
M	FVMQ
E	EPDM
H	HNBR
6	Sensor housing
NN	Standard stainless steel housing
SN	Special 316 stainless steel housing
NR	Standard stainless steel housing with rupture disc
SR	Special 316 stainless steel housing housing with rupture disc
NS	Standard stainless steel housing with rupture disc, G 3/4" male thread drain connection
SS	316 stainless steel special housing with rupture disc, G 3/4" male thread drain connection
7	Process connection
Axx	ANSI RF flange as specified in the data sheet/nameplate
Rxx	ANSI RTJ flange as specified in the data sheet/nameplate
Dxx	DIN flange as specified in the data sheet/nameplate
Jxx	JIS flange as specified in the data sheet/nameplate
Gxx	G-thread as specified in the data sheet/nameplate
Nxx	NPT thread as specified in the data sheet/nameplate
Mxx	Autoclave connection as specified in the data sheet/nameplate
Hxx	Hub connection as specified in the data sheet/nameplate
Wxx	Swagelok fitting as specified in the data sheet/nameplate

8	Electrical connection to the transmitter
JM	Coated aluminum terminal box
SM	Terminal box made of 316 stainless steel
J2	Integrated RHE 42 Transmitter (aluminum housing)
J5	Integrated RHE 45 transmitter (aluminum housing)
J9	Integrated RHE 49 Transmitter (aluminum housing)
S9	Integrated RHE 49 transmitter (316 stainless steel housing)
TM	Integrated cable, 2 m

9	Explosion protection	Labeling ¹
NN	Without approval	-
A2	ATEX/IECEX Zone 2	Ex II 3G Ex ec IIC T6...T1 Gc Ex ec IIC T6...T1 Gc
A1	ATEX/IECEX Zone 1, 2	Ex II 2G Ex ib IIC T6...T1 Gb Ex ib IIC T6...T1 Gb
A0	ATEX/IECEX Zone 0, 1, 2	Ex II 1G Ex ia IIC T6...T1 Ga Ex ia IIC T6...T1 Ga
C2	cCSAus Class I, Zone 2	Class I, Zone 2, AEx nA IIC T6...T1 Gc
C0	cCSAus Class I, Div. 1, 2, Zone 0, 1, 2	Class I, Div 1, Groups A, B, C and D T6...T1 Class I, Zone 0, AEx ia IIC T6...T1 Ga
AA	ATEX/IECEX Zone 0, 1, 2, Gas Group IIB	Ex II 1G Ex ia IIB T6...T1 Ga Ex ia IIB T6...T1 Ga
AB	ATEX/IECEX Zone 1, 2, Gas Group IIB	Ex II 2G Ex ib IIB T6...T1 Gb Ex ib IIB T6...T1 Gb

¹ The temperature class Tx depends on the sensor type and the fluid temperature range (2). Refer to the nameplate

10	Cable entry / cable gland
NN	Standard for integrated transmitters, as specified in the transmitter data sheet
B1	M20 x 1.5 cable gland (PVC for non-hazardous areas, brass-nickel for hazardous areas)
E1	½" NPT cable entry, no cable gland
E5	M20 x 1.5 cable gland made of 316 stainless steel
E6	½" NPT cable entry made of 316 stainless steel, no cable gland
1B	M20 x 1.5 cable gland upwards/gas application (PVC for non-hazardous areas, brass-nickel for hazardous areas)
1E	½" NPT cable entry upwards gas application, no cable gland

10	Cable entry / cable gland
5E	M20 x 1.5 cable gland made of 316 stainless steel, upwards/gas application
6E	½" NPT cable entry made of 316 stainless steel upwards/gas application, no cable gland
11	Compliance
N	Rheonik standard model in accordance with EN standards (not PED-compliant, not for sale in the EU)
P	Compliance with the Pressure Equipment Directive (PED)
C	Compliance with Canadian Registration No. (CRN)
12	Performance/Conformity Certification
NN	Without certification
R7	OIML R117 Approval
9R	OIML-CS R139 approval for hydrogen
13	Flow calibration
A	Standard – Uncertainty ≤ 0.20% / 3 points
B	Enhanced – Uncertainty ≤ 0.15% / 3 points
G	Premium – Uncertainty ≤ 0.10% / 4 points
U	Ultimate – Uncertainty ≤ 0.05% / 4 points
1	Low Flow – Uncertainty ≤ 0.10% / 4 points
X	Custom calibration
14	Density calibration
N	No density measured
S	Standard, uncertainty as specified in the data sheet
D	Premium, uncertainty as specified in the data sheet
15	Factory Services
D1	Material certificate for wetted parts in accordance with EN 10204 3.1
D2	Pressure test certificate and material certificate for wetted parts in accordance with EN 10204 3.1
FS	Combined factory services, available options:
	D1 Material certificate for wetted parts in accordance with EN 10204 3.1
	D2 Pressure test certificate and material certificate for wetted parts in accordance with EN 10204 3.1
	TP Separate stainless steel tag (tag information only)
	TC Stainless steel nameplate

15 Factory Services		
	F	Removal of residual water from the calibration process using compressed air
	O	Specialized cleaning, water- and grease-free
	7	Dual IP66/67 protection rating
Sensor accessories		
M	Wall mount bracket	
MF	Floor mount bracket	

2.2 Scope of delivery

Depending on your order, the scope of delivery for a RHM sensor may include the following items:

- Sensor, with optional built-in transmitter.
- This manual.
- Declaration of Conformity, if applicable.
- Additional certificates, depending on the scope of delivery.
- Transport locks.
- Optional sealing plugs for transport lock openings.

2.3 Condition as delivered

2.3.1 Inspection upon delivery

- Perform the following checks upon delivery:
 - Check the delivery for damage.
 - Report any damage immediately to the carrier and the sales department.
 - Check that the contents of the package match your order.
 - Check that the nameplate matches the specifications in the order.
 - Remove the documentation from the packaging and keep it for future reference.
 - Keep the shipping packaging in case you need to return the item.

2.4 Important information about the product

2.4.1 Compliance

Depending on the product configuration ordered, declarations of conformity may be included in the scope of delivery. Refer to the documents included with the product.

2.4.2 Product labeling

Nameplate

RHEONIK. Rheonik Messtechnik GmbH Germany, 85235 Odelzhausen, Rudolf-Diesel-Straße 5		Class I, Zone 0, AEx ia IIC T6...T1 Ga		Ex ia IIC T6...T1 Ga		 C US 220495									
		Class I, Div. 1, Groups A, B, C and D T6...T1		CSA 18CA70138578											
Coriolis Flow Sensor RHM06 1" 150lbs		5													
Order Code: M06SE2P2PF010A1JM-NN-U1		6		T6		T5		T4		T3		T2		T1	
Ser. No.: RHM-123456		7		Min Ambient Temp.		-40°C		-40°C		-40°C		-40°C		-40°C	
TAG No.: TAG Number		8		Min Process Temp.		-40°C		-40°C		-40°C		-40°C		-40°C	
Product Group PRESSURE ACCESSORIES				Max Ambient Temp.		65°C		80°C		80°C		80°C		80°C	
Nom. Flow [kg/min]:		25		9		Max Process Temp.		65°C		80°C		115°C		180°C	
Nom. Diam. [DN]:		6 / 25		10 (Tube / Connection)											
PS [barg]:		20		14		PT [barg]:		29		12		Intrinsically Safe Circuits Pins Ui (V) li (mA) Pi (mW) Ci (nF) Li (mH)			
TS [°C]:		-40		50		210		TT [°C]:		20					
Prot. Rating:		IP66 / Type 4X		13		Drive Circuits		1-2		9.3		144		335	
Connection:		1" 150lbs		14		Pickup Circuits		6-7 9-8		7.4		29		54	
Wetted Parts:		15		1,4410/1,4501		Temperature Sensor		3-4 5-4		7.4		58		107	
Test Date / MFG Date:		13.01.2026 / 2026		Made in Germany											
 0036 0044		Flashing Liquids not allowed Fluid group 1 EN 13480 Category II 17		II 2G Ex ib IIC T6...T1 Gb		BVS 17 ATEX E 074 X									
				Ex ib IIC T6...T1 Gb		IECEx BVS 17.0063X									
Extended order code: M#06P-E2D2-PF0NN-A06JM-U1B1NNN-GSFS															

- | | | | |
|---|--|----|---|
| 1 | Company name and full address of the manufacturer | 10 | Nominal diameter of measurement tube and fittings |
| 2 | Hazard classifications and certification numbers | 11 | Maximum operating pressure as a function of fluid temperature |
| 3 | CE marking and notified body | 12 | Test pressure and test temperature |
| 4 | Table of safety limits for intrinsically safe circuits | 13 | Protection rating |
| 5 | Product name | 14 | Process connection |
| 6 | Order code | 15 | Material of wetted parts, including seal material (if applicable) |
| 7 | Serial number | 16 | Test date, date of manufacture |
| 8 | Optional: Custom tag number of the sensor | 17 | Information on pressure equipment certification (if applicable) |
| 9 | Nominal flow rate | | |

2.5 Technical specifications

2.5.1 Features

You can find the specifications for your specific sensor on the nameplate and in the data sheet at <https://www.rheonik.com/>.

2.5.2 Dimensions and weights

2.5.2.1 Net weights

The weight specifications for sensors are estimates based on Standard connectors PN16/PN40.

Sensor	Net weight (kg)	Transmitter	Net weight (kg)
RHM 30	58.0	RHE 46	0.2
RHM 40	100.0	RHE 49(integral)	0.2
RHM 60	235.0	Various	Negligible
RHM 80	433.0	Various	Negligible
RHM 100	550.0	Various	Negligible
RHM 160	670.0	Various	Negligible

2.5.2.2 Shipment dimensions and gross weights

Typical weight for a unit consisting of RHM and RHE 28 transmitter. RHM Sensors size 30 and larger are packaged separately.

Sensor	Packaging	L x W x H [cm]	Gross weight (kg)
RHM 30	Wooden crate in accordance with ISPM 15	125 x 80 x 63	115.0
RHM 40	Wooden crate in accordance with ISPM 15	150 x 100 x 71	180.0
RHM 60	Wooden crate in accordance with ISPM 15	180 x 120 x 75	310.0
RHM 80	Wooden crate in accordance with ISPM 15	220 x 160 x 90	550.0
RHM 100	Wooden crate in accordance with ISPM 15	220 x 160 x 90	750.0
RHM 160	Wooden crate in accordance with ISPM 15	240 x 190 x 120	1150.0

2.5.2.3 Installation dimensions

You can find the installation dimensions for your sensor in the data sheet at:

<https://www.rheonik.com/>

2.5.3 Environmental conditions

! Important

Storage and operation outside the specified environmental conditions will result in damage to the sensor and void the warranty.

Condition	Storage	Operation
Ambient temperature	Standard: -50 °C to +80 °C.	
	For models intended for use in hazardous areas, also observe the information on the nameplate, as well as A.2 Thermal safety limits for RHM sensors, p. 76 .	
	Process temperature	N/A
	Maximum humidity	95%, non-condensing
Moisture	Store in a dry place	Observe the protection rating indicated on the nameplate.
Dust	Store in a dust-free environment	Observe the protection rating indicated on the nameplate.
Location (e.g. elevation above sea level)	up to 3000 m above sea level. Consult Rheonik before using this product at elevations above 3,000 meters above sea level .	
Resistance to acids and bases	<ul style="list-style-type: none"> ➤ Observe the materials of sensor and seal as indicated on the nameplate. It is the operator's sole responsibility to verify the material compatibility and suitability of the measuring system for the specific application.	
Explosion protection	N/A – no ignition source when not in use	Depending on the model ordered. Refer to the explosion protection certificate, if included.
EMC environment	Strong magnetic fields can cause malfunctions. <ul style="list-style-type: none"> ➤ Keep a sufficient distance from motors, turbomachinery, large transformers, electrically operated valves, power contactors, and similar equipment. ➤ Comply with the requirements of the EMC Directive 2014/30/EU. 	

Sudden temperature changes reduce the sensor's accuracy and service life. The maximum permissible rate of temperature change is 1 °C/s. Minimize temperature changes during operation by taking the following measures:

- Insulate the sensor
- Install trace heating

Refer to [5.3.6 Insulation](#), p. 54.

2.5.4 Emissions

When used as intended, no emissions are expected from Rheonik sensors.

3 Safety

! Important

Strictly observe the following safety instructions to ensure the safe use of the product.

The product must only be operated in perfect condition:

- No visible damage.
- No leakage of the measured fluid.
- No unauthorized modifications have been made to the product.

The operator must review this Operation Manual, and in particular the following safety instructions, with regard to their specific application. The operator must conduct a risk assessment for this purpose. Based on this, the operator must train its personnel on the safe use of the product throughout its entire lifecycle. Local occupational safety regulations must be observed.

Changes to the product may only be made if they have been authorized by Rheonik. Unauthorized modifications to the product may result in unforeseeable hazards. Unauthorized modifications will void the warranty.

Determining the suitability of the product for a specific application is the sole responsibility of the operator. Rheonik assumes no liability in this regard.

3.1 Disclaimer

Rheonik assumes no liability for losses and/or consequential damages resulting from the use of this product in life-support systems, such as in medicine, automobiles, aviation, marine vessels, or mining.

Likewise, Rheonik excludes liability for any loss or damage resulting from the improper use of its products.

Rheonik is not liable for loss of production and/or consequential damages resulting from the use of the product, unless such liability has been expressly agreed upon in a contract.

3.2 Intended use

A RHM sensor is intended solely for use as part of a Rheonik measurement system. A Rheonik measurement system always consists of a RHM sensor and a RHE transmitter connected to the sensor.

The intended use of a Rheonik measurement system is exclusively for measuring the flow rate, total quantity, density, and temperature of fluids. Fluids can be gases, liquids, or two-phase mixtures. To perform the measurement, the measuring system is permanently installed in a customer-supplied pipe and the fluid to be measured flows through it.

Intended use requires that the following conditions be met:

- Pressure and temperature ranges as indicated on the nameplate.
- Environmental conditions as specified in Chapter [2.5.3 Environmental conditions](#), p. 23.
- Restrictions on use as indicated on the nameplate, e.g., for use in hazardous areas.
- Restrictions on use as specified in the Declaration of Conformity.

- The materials used in all components of the measurement system must be resistant to the process media at the expected pressures and temperatures, as well as to the expected environmental conditions.
- Handle the product in accordance with the included documentation throughout its entire lifecycle.
- Do not make any modifications to the product unless they have been explicitly approved by Rheonik.

The expected service life under normal use is 25 years.

3.3 Improper use

Improper use of the product may compromise measurement accuracy and result in personal injury or property damage, e.g., due to malfunctions or material failure.

Reasonably foreseeable misuse

- Modifications to the product not approved by Rheonik.
- Use with transmitters from other manufacturers.
- Use in environmental conditions outside the specified range. Refer to the nameplate and Chapter [2.5.3 Environmental conditions, p. 23](#).
- Failure to comply with the restrictions on use specified in the Declaration of Conformity. In particular, use in hazardous areas without the appropriate approval in accordance with applicable local regulations.
- Failure to comply with: The resistance of the measuring system's components to process media at the expected pressures and temperatures, as well as their resistance to expected environmental influences.
- Failure to follow the included documentation.

Consequences of improper use

Improper use may result in damage to the product. This can cause the fluid to leak uncontrollably or the housing to burst.

In the event of improper use, all product approvals as well as all warranty claims become void.

3.4 Personnel qualification

The operator must ensure that personnel possess the required qualifications for the respective activity.

Activity	Responsible	Qualification
Transport	Operator	Warehouse logistics specialist
Mechanical installation	Operator	Industrial mechanic
Electrical connection	Operator	Certified electrician
Commissioning, configuration	Operator	Trained personnel
Operation	Operator	Trained personnel

Activity	Responsible	Qualification
Maintenance, inspection	Operator	Trained personnel
Troubleshooting, repair	Operator	Trained personnel
Decommissioning, dismantling: mechanical	Operator	Industrial mechanic
Decommissioning, dismantling: electrical	Operator	Certified electrician
Disposal	Operator	Waste management officer
Storage	Operator	Warehouse logistics specialist

3.5 Safety instructions

The sensor's surfaces may be hot or cold, depending on the temperature of the fluid flowing through it. There is a risk of burns or frostbite.

- Install thermal insulation on the sensor if necessary.

If your process has increased cleanliness and hygiene requirements, e.g., for applications in the food and pharmaceutical sectors:

- Thoroughly clean the sensor's wetted parts before using it for the first time.

3.5.1 Protective devices and safety measures

Depending on the configuration ordered, the product may be equipped with a rupture disc. If your product is equipped with a rupture disc:

- Install the product so that the rupture disc is not directed at personnel or sensitive equipment in the event of a rupture.

3.5.2 Operating limits

The sensor's permissible temperature and pressure ranges are specified on the nameplate.

- Operate the sensor only within the specified temperature and pressure ranges.

The nominal pressure rating of the connection flanges may be higher than the maximum operating pressure of the sensor. Only the maximum operating pressure specified on the nameplate is permitted.

The flange connections were designed based on a gasket factor of $m = 1.1$. If seals with higher gasket factors are used, the flanges must be redesigned.

Some components of systems, such as piston pumps, can cause pressure spikes.

- When designing your process, make sure that the permissible pressure range is maintained even during expected pressure spikes.

The maximum permissible number of 1,000 pressure cycles, as specified in EN 13480-3, Section 10.3.1, must not be exceeded.

3.5.3 Material durability and wear

It is the operator's sole responsibility to verify the material compatibility and suitability of the measuring system for the specific application.

- Verify the long-term durability of the materials used in all components of the measurement system.

This includes resistance to process media at the expected pressures and temperatures, as well as resistance to expected environmental influences.

Abrasive media can gradually reduce the wall thickness of the measurement tubes due to wear. This can reduce the sensor's pressure resistance.

If corrosion or abrasive media are expected in your process, Rheonik recommends regularly conducting a NDT (non-destructive testing) program to monitor the condition of the sensor. Please contact Rheonik for assistance in setting up this program.

3.5.4 Explosion protection

RHM Sensors can be certified for use in hazardous areas if they are connected to a transmitter that is certified for such use.

3.5.4.1 System for use in hazardous areas

Install a Rheonik system for use in a hazardous area in one of the following configurations:

- Intrinsically safe RHM sensor.
- RHM sensor with type of protection ec or nA.

Intrinsically safe RHM sensor

The system consists of the following components:

- Intrinsically safe RHM sensor.
- Certified transmitter, Type RHE or equivalent, with an integrated or external barrier.

Depending on the specific certification, the sensor may be used in the following zones:

- Zone 0, 1, or 2.
- Div 1 or Div 2 in the U.S. market.

Transmitters with barriers are available for the following zones:

- Zone 1 or 2.
- Div 1 or Div 2 in the U.S. market.

Observe the certification and the nameplates of the sensor and the transmitter.

RHM Sensor with type of protection ec or nA

The system consists of a RHM sensor and any model of RHE transmitter.

You can use a RHM sensor with an "Ex ec" or "Ex nA" type of protection in Zone 2.

3.5.4.2 Installation in a hazardous area

- Refer to the information in Chapters [A.1 Electrical safety limits for RHM sensors, p. 75](#) and [A.2 Thermal safety limits for RHM sensors, p. 76](#).
- Install the measurement system in accordance with the applicable standards for electrical installations in hazardous areas.
- Read this user manual carefully before installing the RHM sensor.
- Mechanical and electrical installation and commissioning must be performed only by qualified personnel who have been trained in explosion protection.
- Comply with all national regulations regarding the installation and repair of equipment in hazardous areas.
- Rheonik RHM sensors are generally maintenance-free and contain no user-serviceable parts. Contact your local sales/support representative or Rheonik customer support for service or repairs.

If the device is opened, the hazardous area certification becomes invalid.

- The temperature class must match the values on the nameplate. The temperature class is based on the ambient temperature and the fluid temperature.
- The maximum permissible fluid temperatures can be found in the Chapter [A.2 Thermal safety limits for RHM sensors, p. 76](#).
- Use only the cable provided by Rheonik to connect RHM and RHE. Consult Rheonik before using any other cables. In the case of intrinsically safe RHM, the cable between RHM and RHE is intrinsically safe.
- For safety reasons, the total cable length between a RHM sensor and the RHE transmitter must not exceed 100 meters.
- The ARHE-C4 and ARHE-C6 connection cables are designed for temperatures ranging from -50 °C to +105 °C. Avoid higher temperatures. Temporary temperatures below -50 °C are permissible if the cable is installed in a protective conduit.
- Secure the cable near the RHM so that no mechanical stress is applied to the cable gland of the RHM.
- Seal all unused cable glands and openings with blind plugs.

- Make sure that cable glands and blind plugs not supplied by Rheonik comply with all national requirements.
- According to the specifications on the nameplate, the device may be used under conditions where ignitable atmospheres consisting of a mixture of air and other gases, vapors, or dust are present. This device is not suitable for use in mines.
- RHM Sensors are available for Zones 0 and 1 (Ex ia or Ex ib), for Zone 2 (Ex ec), and for Division 1 and 2. You can find the applicable classification on the nameplate.
- For information on installing the RHE transmitter, refer to the RHE manual.
- Separate the field wiring of different intrinsically safe circuits using insulation with a thickness of at least 0.25 mm on each conductor.
- Ground RHM with hazardous area approvals "C0", "CB", "C2", or "CN":
Devices with connection type Sx have a grounding terminal on the stainless steel terminal box.
All other devices have an M6 screw with a lock washer on the RHM.

3.5.4.3 Additional information for devices with CSA certification

The following limits apply to safe operation in hazardous areas.

Parameter	Value/Note
Electrical specifications	Refer to A.1 Electrical safety limits for RHM sensors, p. 75 and the information on the nameplate.
Operating temperatures	Refer to A.2 Thermal safety limits for RHM sensors, p. 76 and the information on the nameplate.
Fluid/Gas pressure	Refer to the nameplate.
Pollution degree	3
Installation category	I
Humidity	0 to 100% relative humidity
Elevation (above sea level)	up to 3,000 m (higher maximum elevation available upon request)
Electrical connection	to a Class 2 circuit
Protection rating (IP rating)	Refer to 5.3.7 IP protection rating, p. 54 and the information on the nameplate.
For outdoor use	Approved

3.6 Minimum clearances



Rheonik recommends leaving a minimum clearance of 10 cm around the sensor to ensure accessibility.

Strong magnetic fields can cause malfunctions.

- Keep a sufficient distance from motors, turbomachinery, large transformers, electrically operated valves, power contactors, and similar equipment.
- Comply with the requirements of the EMC Directive 2014/30/EU.

3.7 Safety signs

The following safety signs are affixed to the RHM sensor.

Safety signs	Meaning
 <p>PLEASE NOTE P_{max} is lower than flange rating See label for details</p>	<p>The nominal pressure rating of the connection flanges may be higher than the maximum operating pressure of the sensor. Only the maximum operating pressure specified on the nameplate is permitted.</p>
 <p>CAUTION</p> <p>PRESSURE RELIEF ZONE Escaping pressure can cause severe injury or death Stay clear of area</p>	<p>Depending on the configuration ordered, the product may be equipped with a rupture disc. If your product is equipped with a rupture disc:</p> <ul style="list-style-type: none"> ➤ Install the product so that the rupture disc is not directed at personnel or sensitive equipment in the event of a rupture.

3.8 Safety-related emissions

When used as intended, no emissions are expected from Rheonik sensors.

4 Design and function

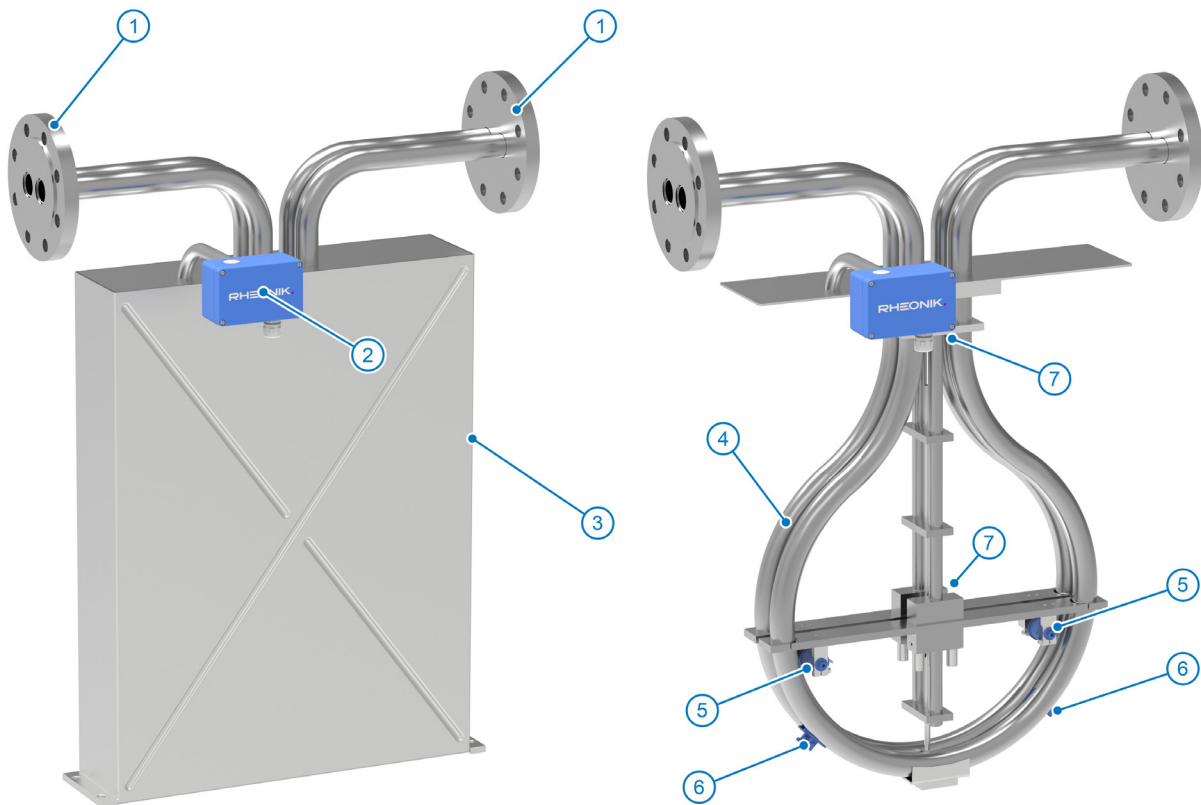

Fig. 1: Sensor design: exterior view with housing. Schematic diagram; model-specific design is similar.

- | | | | |
|---|---------------------|---|----------------------------------|
| 1 | Process connections | 5 | Drive coils |
| 2 | Terminal box | 6 | Pickup coils |
| 3 | Housing | 7 | Positions of temperature sensors |
| 4 | Measurement tubes | | |

The operating principle of RHM sensors is based on the Coriolis effect.

Density measurement

A RHM sensor contains two parallel measurement tubes (4). The measurement tubes feature a curved design. The measurement tubes are driven to oscillate by drive coils (4). Similar to a guitar string, the measurement tubes oscillate at a defined frequency, the twist frequency. Once a fluid flows through the measurement tubes, there is additional mass in the measurement tubes, which changes the twist frequency. This change in the twist frequency depends on the density of the fluid.

Mass flow measurement

The two measurement tubes are excited in such a way that their oscillation amplitudes are opposite. If there is no flow through the measurement tubes, this corresponds to a 180° phase shift in the oscillations. The direction of oscillation of the measurement tubes is perpendicular to the direction of fluid flow through the measurement tubes. This causes a cyclic displacement of the fluid, which results in a counterforce known as the Coriolis force. This force leads to a superimposed bending of the measurement tubes and creates a phase shift in their oscillations. The magnitude of the phase shift depends on the flow rate.

Signal processing

The twist frequencies of the measurement tubes are measured by pickup coils (6). The RHE transmitter calculates the following values:

- The fluid density from the change in twist frequency.
- The mass flow rate from the change in phase shift.
- The volumetric flow rate from the mass flow rate and density.

Additional Pt1000 elements (7) are mounted on the RHM sensor. These are used to measure the fluid temperature. The measured temperature is also used for temperature compensation of mass and density.

5 Transport and installation

5.1 Safety

Mechanical installation and electrical connection must be performed only by sufficiently qualified personnel. Refer to chapter [3.4 Personnel qualification](#), p. 26.

The RHM sensor's wetted parts are pressurized during operation. Improper connection of the sensor can lead to leaks.

- Prior to installation, secure any open piping using appropriate measures, such as shutting off the flow or installing blinds. The operator must assess the suitability of the measures based on the specific application.
- Comply with all locally applicable safety regulations.

5.2 Packaging and transportation

RHM sensors are shipped in cartons or in transport crates with screw-on covers.

Orientation markings are affixed to the exterior of original Rheonik packaging:

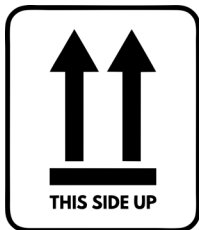

NOTICE

Transport damage

- Observe the orientation markings on the packaging.
- The maximum stacking height is limited to two boxes.
- Use the transport locks provided. Refer to Chapter [5.2.2.2 Transport locks.](#), p. 39.
- Make sure the product remains dry throughout transport, for example by using appropriate desiccants.
- For ocean freight, use only seawater-resistant shipping crates.
- Avoid shock loads during transportation.
- Use shock-absorbing shipping packaging.

5.2.1 Removing the product from the packaging

5.2.1.1 Carton



Personnel

- ✓ 1–2 people, depending on the sensor's weight and the operator's risk assessment. [2.5.2.1 Net weights, p. 22](#)



Required support equipment

- ✓ Cutter
- ✓ For sensor sizes 20 and larger: A crane is recommended.
- ✓ For sensor sizes 20 and larger: A round sling or other suitable lifting device.



Proceeding

1. Carefully open the box at the top.
2. If necessary: Attach a round sling or a suitable lifting device to the sensor and the crane.
Refer to [5.2.2.1 Lifting points, p. 37](#).
3. Carefully lift the sensor out of the box.
4. Remove the outer packaging.



Closing requirements

Dispose of the packaging in accordance with local waste disposal regulations.

5.2.1.2 Transport crate



Personnel

- ✓ 2 people



Required support equipment

- ✓ Cordless screwdriver
- ✓ A round sling or other suitable lifting device.
- ✓ Crane



Proceeding

1. Remove all the mounting screws from the cover.
2. Remove the cover.
3. Remove the protective wrap.
4. If available: Loosen the mounting screws on the sensor base.
5. Loosen the four shipping blocks.
6. Attach a round sling or a suitable lifting device to the sensor and the crane.
Refer to [5.2.2.1 Lifting points, p. 37](#).

7. Carefully lift the sensor out of the transport crate.



Closing requirements

Dispose of the packaging in accordance with local waste disposal regulations.

5.2.2 Transport

5.2.2.1 Lifting points

NOTICE

Damage to the sensor

- Do not lift the sensor by the terminal box or the purge connections.
- Lift the sensor only by the designated lifting points.
- Use appropriate lifting equipment.

Lift by the sensor housing

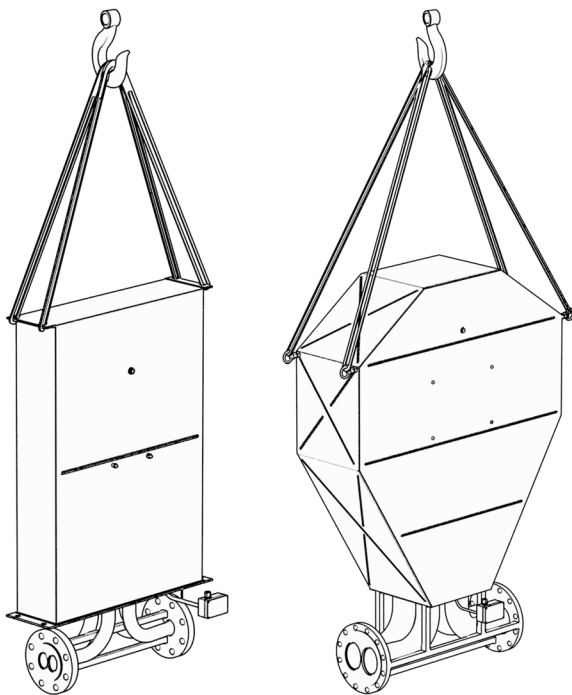

Fig. 2: Lifting eyes on sensor housings

- Use all four lifting eyes.

Lifting using tubes

Fig. 3: Lifting using tubes

- Attach the lifting device below the pipes, not under the crossbeams.

5.2.2.2 Transport locks.

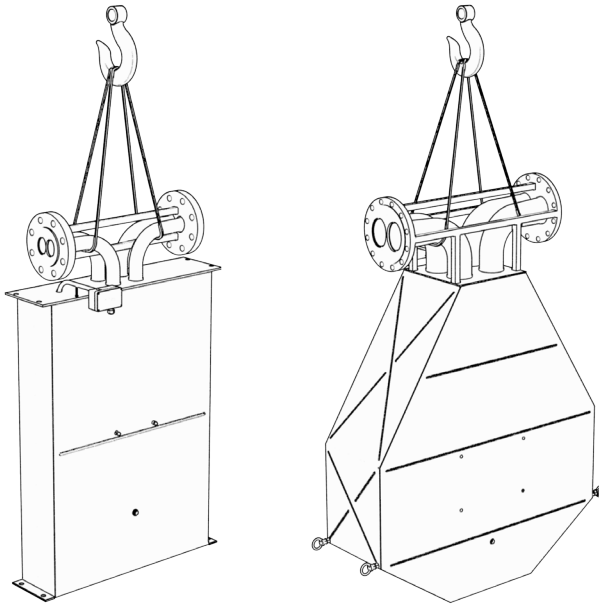
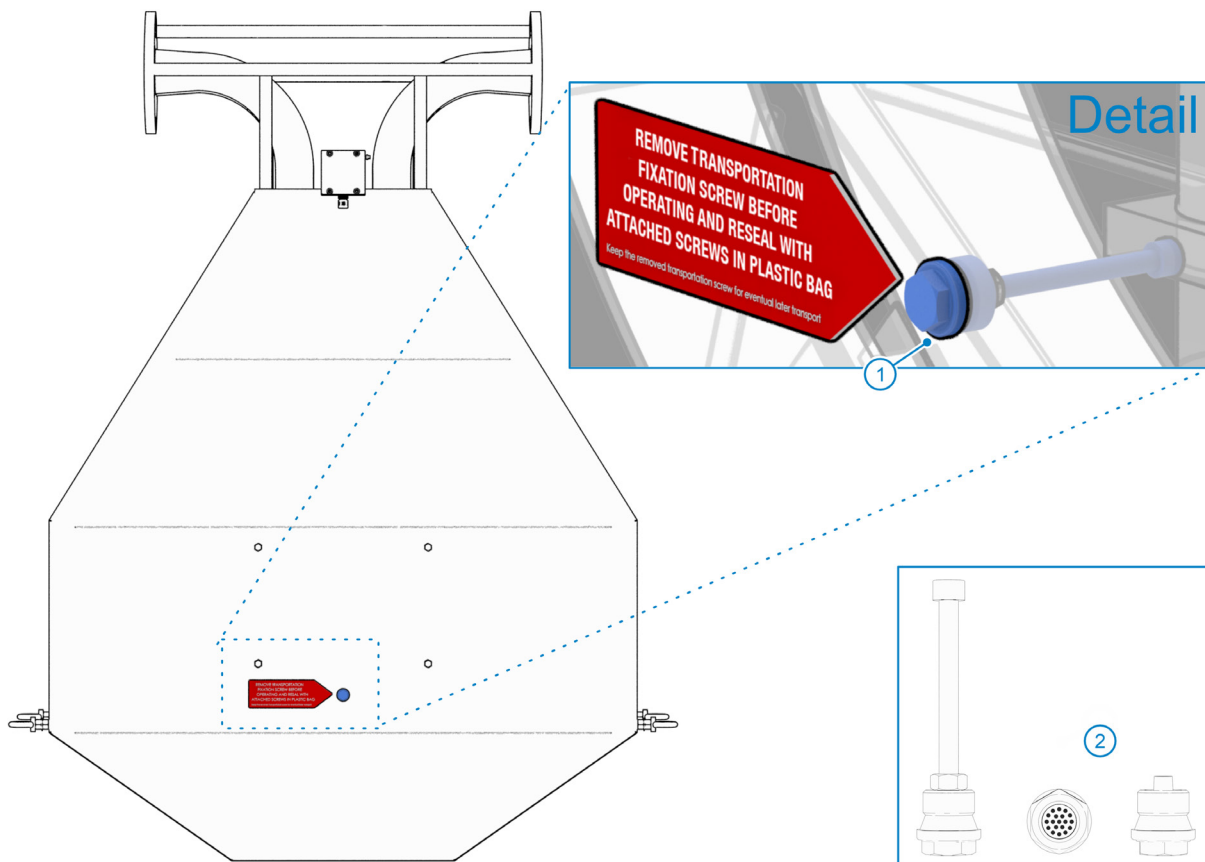

Fig. 4: Transport locks.

RHM sensors size 60 and larger are equipped with transport locks (1).

- Before putting the sensor into service, remove the transport locks on the front and back.
- Seal the openings with the plugs provided (2) to ensure the integrity of the sensor housing.

RHM size	Transport locks.
015, 02, 03, 04, 06, 10, 15, 20, 30, 40	No
60, 80, 100, 160	Yes

5.3 Installation

The RHM sensor is typically installed in a suspended position. Other orientations are possible; refer to [5.3.2 Installation orientation, p. 42](#).

Use appropriate mounting hardware. Refer to Chapter [5.3.5.1 Supports on pipes, p. 52](#).

The correct installation orientation and position depend on the type and composition of the medium. Clarify the following points prior to starting the planning process:

- Is the medium gaseous or liquid?
- Is it a two-phase mixture:
 - Liquid droplets or solids in a gaseous medium.
 - Solids in a liquid medium.
 - Gas bubbles in a liquid medium.

5.3.1 Best practices

- Design the installation to prevent cavitation and the outgassing of dissolved gases. Refer to Chapter [5.3.3.4 Cavitation, outgassing, evaporation, p. 49](#).
- Whenever possible, place valves and fittings on the outlet side of the sensor.
- To perform a zero-point calibration, absolutely leak-tight shut-off valves are required on both the inlet and outlet sides of the sensor. Refer to Chapter [5.3.2.3 Shut-off valves for zero-point calibration, p. 45](#).
- Observe the specified flow direction of the sensor whenever possible. The direction can be indicated by an arrow on the terminal box.:



If this is not possible, you can reverse the positive flow direction in the transmitter.

- Always mount RHM sensors to a solid foundation using supports. Refer to Chapter [5.3.5 Supports, p. 52](#).
- Keep a minimum clearance of 10 cm from the sensor on all sides to ensure access for installation and maintenance.
- If Rheonik sensors are installed too close to each other, crosstalk may occur between them. Crosstalk affects measurement accuracy, especially at low flow rates. Always install sensors at a sufficient distance from one another.
- Straight inlet and outlet sections are not required for Rheonik sensors.
- Avoid "out-of-plane" installation orientations for design type PF. If "out-of-plane" cannot be avoided, install the sensor with a straight inlet section. The length of this inlet section must be at least 10 times the diameter of the pipe. Refer to Chapter [5.3.3.5 Out of plane, p. 50](#).

- Before commissioning, vent the process piping upstream and downstream of the sensor.
- Ensure measurement tubes are always filled with process fluid, where process conditions permit.

5.3.2 Installation orientation

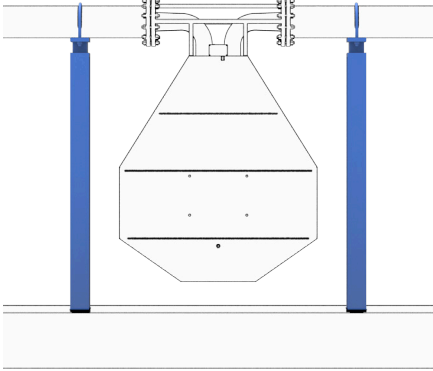
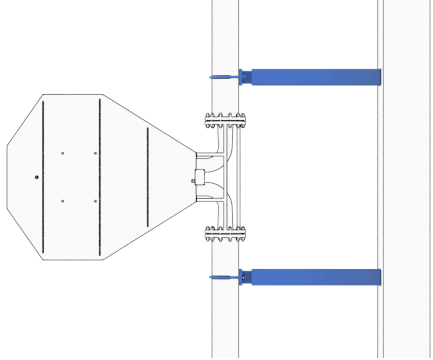
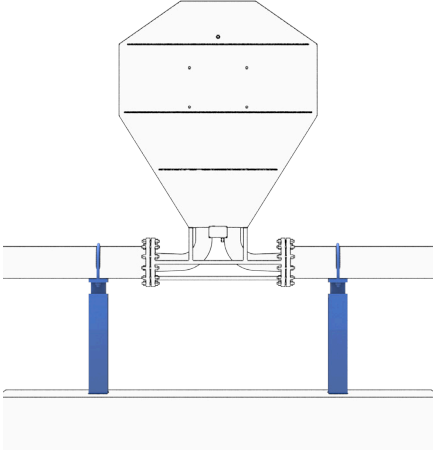
Installation orientation Supports shown in blue	Use case
<p>Horizontal, housing at the bottom</p> 	<p>Preferred installation orientation for measuring liquids. The accumulation of gas bubbles is prevented</p> <p>Avoid for two-phase mixtures:</p> <ul style="list-style-type: none"> • Gas mixed with liquids or solids. • Liquid containing solids. <p>Refer to 5.3.2.2 Two-phase mixture, p. 44.</p>
<p>Vertical, flow from bottom to top</p> 	<p>Possible installation orientation for</p> <ul style="list-style-type: none"> • Liquid medium. • Two-phase mixture of liquid and gas. <p>Facilitates the passage of entrained gas bubbles.</p> <p>Avoid for two-phase mixture of liquid and solids.</p> <p>Avoid if a measurement accuracy of less than 0.1% is required.</p>
<p>Horizontal, housing on top</p> 	<p>Preferred installation orientation for measuring gases. Droplets can be separated from gas more easily.</p> <p>Not suitable for two-phase mixtures of liquid and gas.</p> <p>Refer to 5.3.2.2 Two-phase mixture, p. 44.</p>

5.3.2.1 Alignment of process connections

NOTICE

Improperly aligned connections and installation under mechanical stress affect the measurement performance and can damage the sensor.

- The dimensions and orientation of the on-site connections must match the sensor's dimensions.
- The surfaces of the connection flanges must be parallel to each other and aligned vertically.

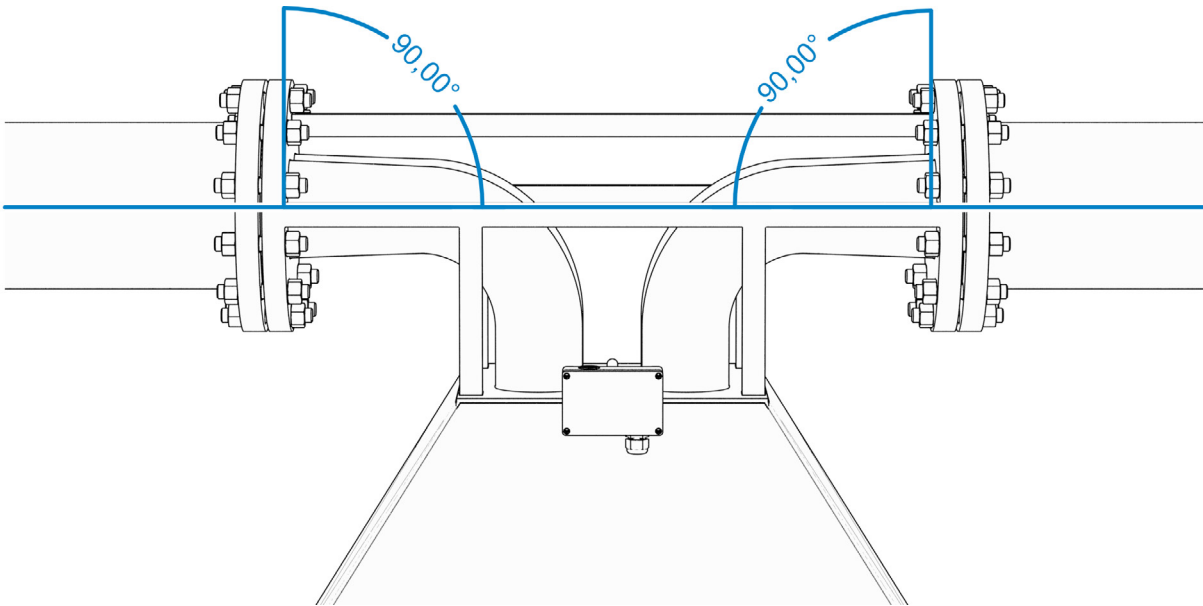

Fig. 5: Connection flanges parallel and square

5.3.2.2 Two-phase mixture

! *Important*

Measuring two-phase mixtures always results in a reduction in measurement accuracy and can cause the measuring device to malfunction temporarily.

If possible, avoid measuring two-phase mixtures.

The effect of a two-phase mixture on measurement accuracy depends on your specific application. As a general rule, measurement accuracy is compromised to a greater extent the higher the proportion of the second phase (gas or solid), the larger the bubbles or particles, and the more heterogeneous the mixture.

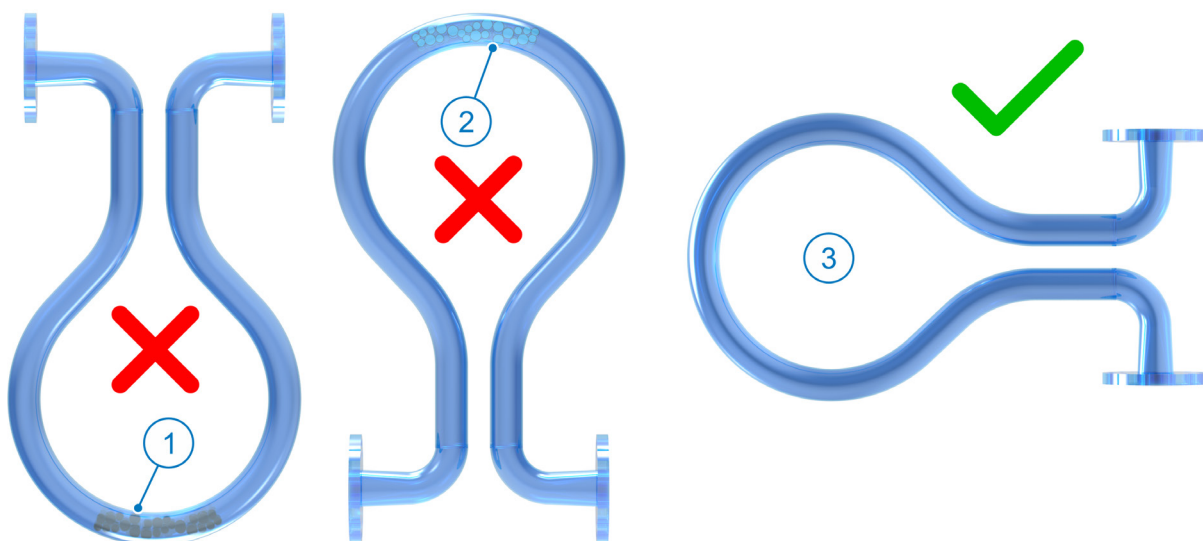

Fig. 6: Two-phase mixture: liquid/solid (left), liquid/gaseous (center)

No.	Installation orientation	Avoid	Reasoning
1	Horizontal, housing at the bottom	Avoid for two-phase mixtures: <ul style="list-style-type: none"> • Gas mixed with liquids or solids. • Liquid containing solids. 	Low point in the lower half of the measurement tube; potential accumulation (1) of liquid or solids in the measurement tube.
2	Horizontal, housing on top	Avoid for two-phase mixtures of liquid and gas.	High point in the upper half of the measurement tubes; potential accumulation of gas (2) in the measurement tube.
3	Vertical, flow from bottom to top	Preferred installation orientation	Easier flushing of liquids or solids from the measurement tube.

5.3.2.3 Shut-off valves for zero-point calibration

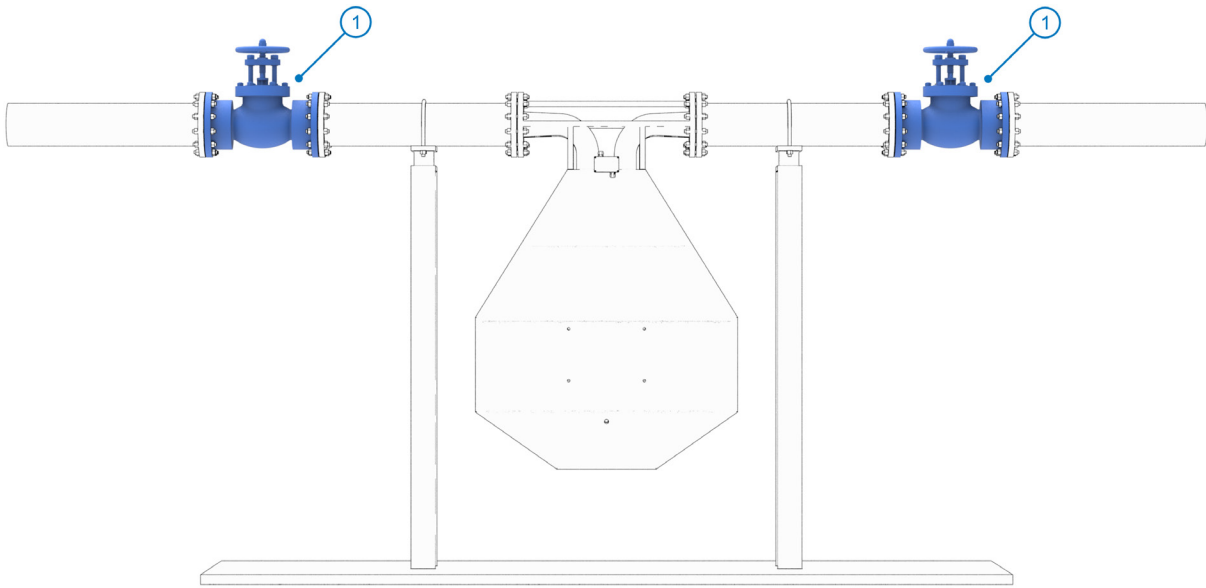

Fig. 7: Shut-off valves for zero-point calibration

To perform a zero-point calibration, absolutely leak-tight shut-off valves (1) are required on both the inlet and outlet sides of the sensor. Refer to the RHE transmitter's manual.

5.3.3 Installation position

5.3.3.1 Recommended installation positions

Rheonik recommends the following installation positions:

Installation position	Recommendation
-----------------------	----------------

On the discharge side of pumps

Prevention of cavitation by ensuring sufficient pressure in the wetted parts.

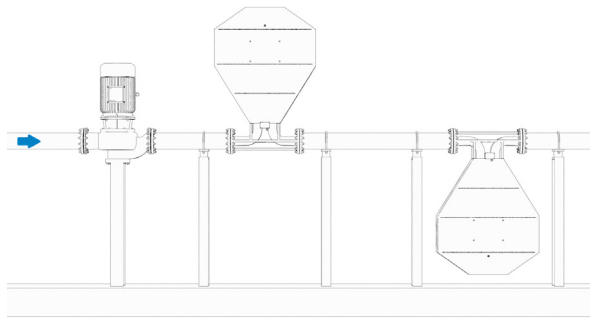

At the lowest point of a vertical riser

Prevention of cavitation by ensuring sufficient pressure in the wetted parts.
Ensure the measurement tubes remain filled with process fluid.

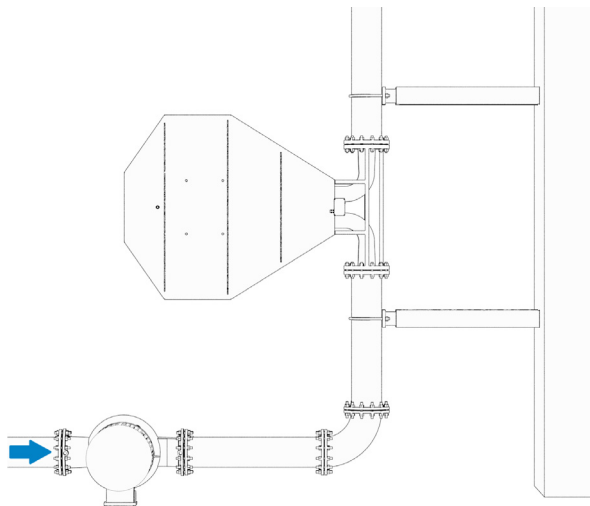

5.3.3.2 Critical installation positions

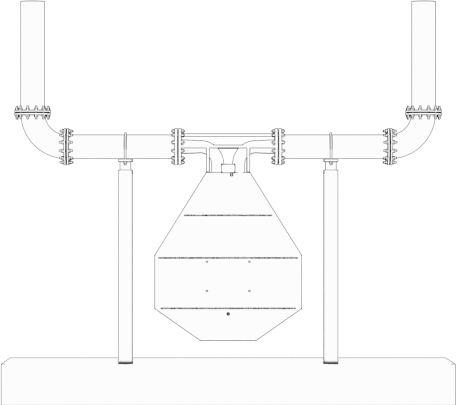
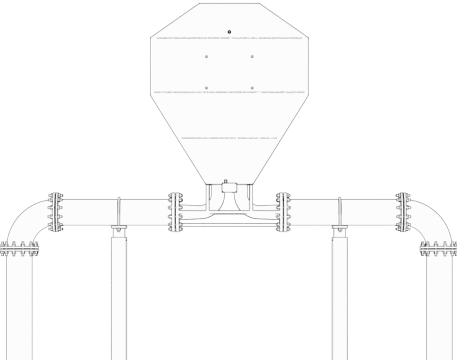
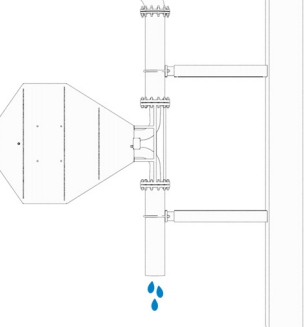
Installation position	Recommendation
<p data-bbox="161 344 293 376">Low point</p> 	<p data-bbox="644 344 1326 488">Avoid for gaseous media that may contain liquids. Avoid for liquid media that may contain solids. Potential accumulation of liquid or solid material at the lowest point.</p>
<p data-bbox="161 853 300 884">High point</p> 	<p data-bbox="644 853 1358 925">Avoid for liquid media that may contain gas bubbles. Potential accumulation of gas at the high point.</p>
<p data-bbox="161 1312 293 1344">Downpipe</p> 	<p data-bbox="644 1312 1318 1413">Generally avoid if possible. The measurement tubes may run empty. Refer to 5.3.3.3 Downpipe, p. 48.</p>

5.3.3.3 Downpipe

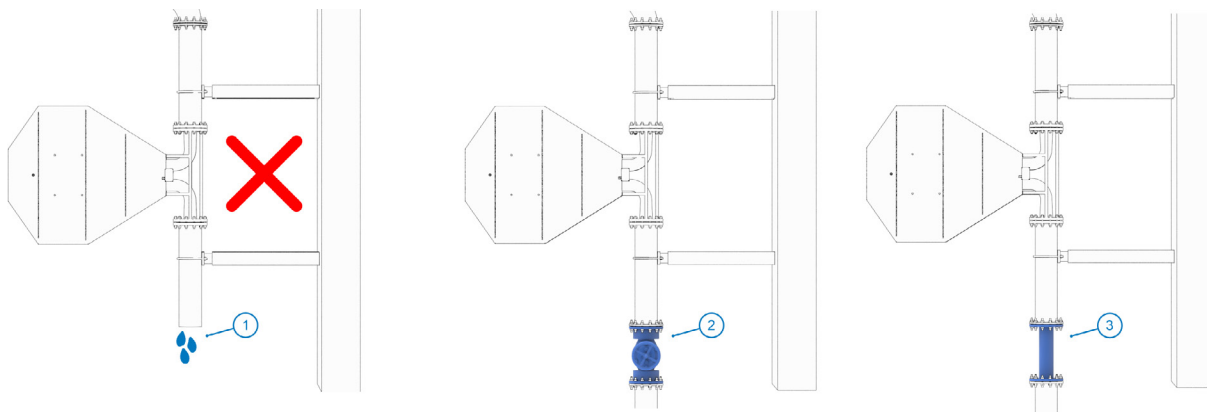

Fig. 8: Downpipe

No.	Explanation
1	Free pipe outlet
2	Valve
3	Flow restriction: reducer or orifice plate

Rheonik recommends avoiding the installation of RHM sensors in a downpipe. Observe the following recommendations if installing a RHM sensor in a downpipe is unavoidable.

- Avoid installation at the high point or immediately in front of a free pipe outlet. In these mounting positions, the risk of running empty or gas accumulation is highest.
- Prevent the measurement tubes from running empty. To achieve this, install one of the following elements on the outlet side to reduce the flow rate:
 - Narrowing of the pipe cross-section using a reducer or orifice plate.
 - Reducing the flow rate using a valve.

5.3.3.4 Cavitation, outgassing, evaporation

Cavitation, outgassing, and evaporation can significantly impair measurement accuracy.

Cavitation is caused by the local pressure falling below the vapor pressure of a liquid. The outgassing of dissolved gases and the evaporation of liquids with low vapor pressure are caused by insufficient system pressure.

Avoid cavitation, outgassing, and evaporation of liquids.

- The system pressure must always be higher than the vapor pressure of liquid media.
- Rheonik recommends providing backpressure in the system downstream of the sensor.
- Do not install RHM sensors on the suction side of pumps (1).
- Other components, such as valves, can also cause cavitation. Design all system components to prevent cavitation.
- Optionally, you can install a pressure regulator downstream of the sensor to keep the line pressure above the vapor pressure.

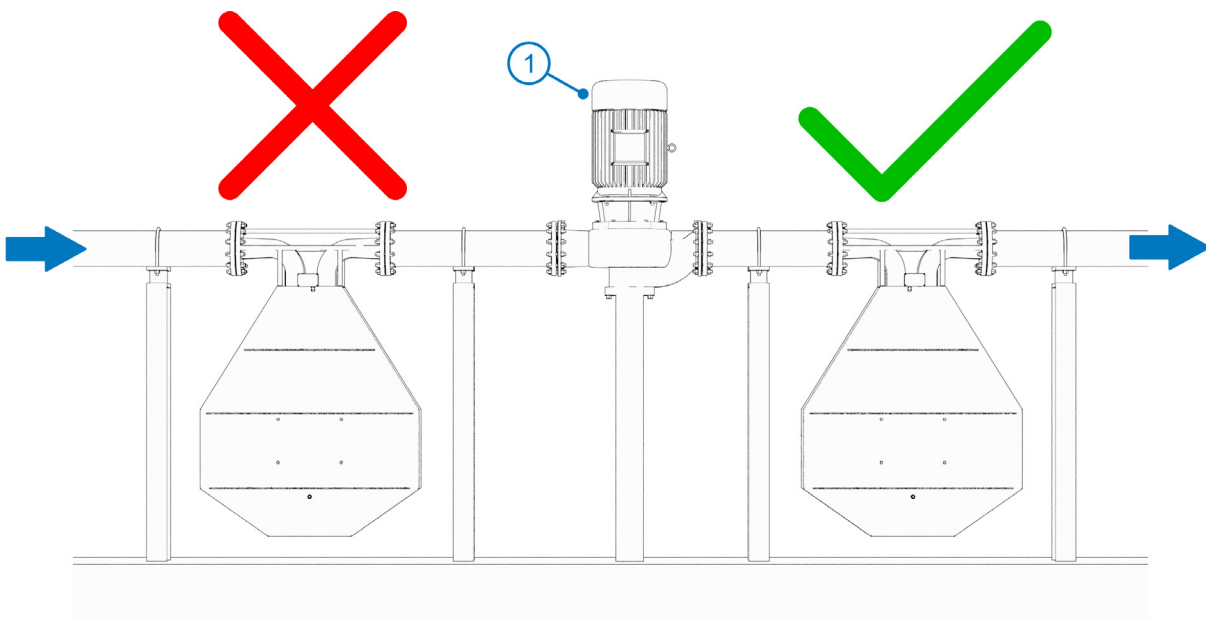

Fig. 9: Sensor installation position downstream of a pump

5.3.3.5 Out of plane

Applies only to design type PF (tube inlets directly in the connection flange). [2.1 Order code, p. 15](#).

"Out of plane" means that there is a bend in the supply pipe near the inlet, and this bend does not lie in the plane of the measurement tubes. Centrifugal forces act on the fluid, which leads to higher flow velocities in one of the two measurement tubes and distorts the measurement result.

Avoid installation positions that are out of plane.

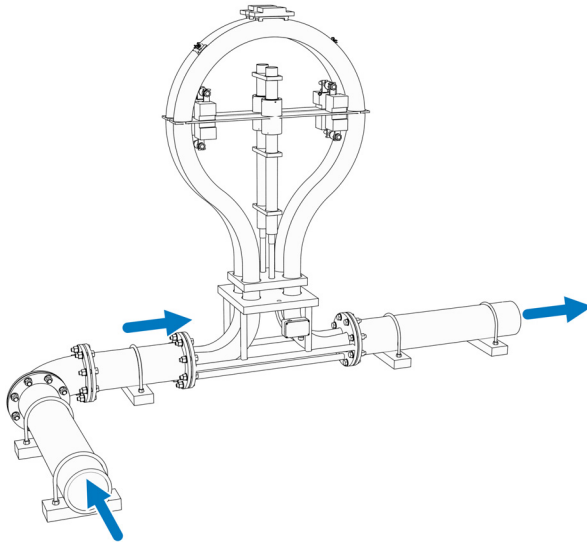

Fig. 10: Out of plane installation orientation. Sensor shown without housing; fluid flow direction shown in blue.

5.3.4 Vibrations

Vibrations impair the sensor's measurement accuracy and may cause damage to the sensor.

- Minimize vibrations by combining the following measures:
 - Install the sensor at a location with as little vibration as possible.
 - Use sturdy pipe clamps to securely attach the sensor to a rigid, non-vibrating surface. Refer to [5.3.5.1 Supports on pipes, p. 52](#).
 - Elastomeric mounts on supports.
 - Mechanical decoupling via flexible hoses used as connectors between the sensor and the rigid piping system.
 - Secure all pipe sections near the sensor that are prone to vibration.
 - Installing the sensor after a pipe bend can further help with mechanical decoupling.
 - The sensor housing must not come into contact with other components or equipment provided by the customer: Prevention of vibration transmission.

5.3.5 Supports

RHM sensors must be secured to the on-site inlet and outlet pipes using supports. Refer to [5.3.5.1 Supports on pipes, p. 52](#).

Additional measures are required for custody transfer; refer to [5.3.5.2 Custody transfer, p. 53](#)

5.3.5.1 Supports on pipes

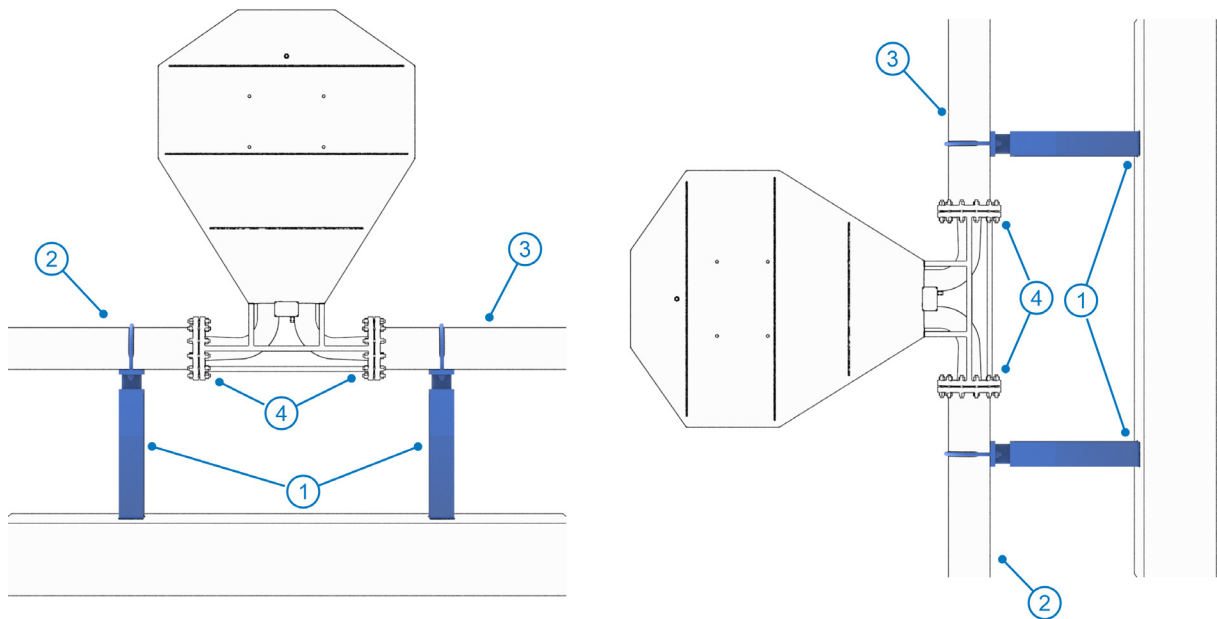

Fig. 11: Supports

When designing the supports, take into account the weight of the sensor [2.5.2 Dimensions and weights, p. 22](#) as well as the load-bearing capacity of the wall or floor.

No significant additional loads must be applied to the sensor during installation or operation.

- Secure the supports to a solid surface or a sturdy wall.
- Attach the RHM sensor to the on-site inlet pipe (2) and outlet pipe (3) using the supports (1).
- Do not attach any supports to the measurement tubes (4) or the housing.

Rheonik recommends mounting the supports as close to the flanges as possible. The distance between the supports must not exceed twice the installation length of the sensor.

5.3.5.2 Custody transfer

For custody transfer, at least one of the following installation options is required.

Minimize mechanical stresses and bending moments to ensure sufficient measurement accuracy.

Minimum requirement: two supports on each side

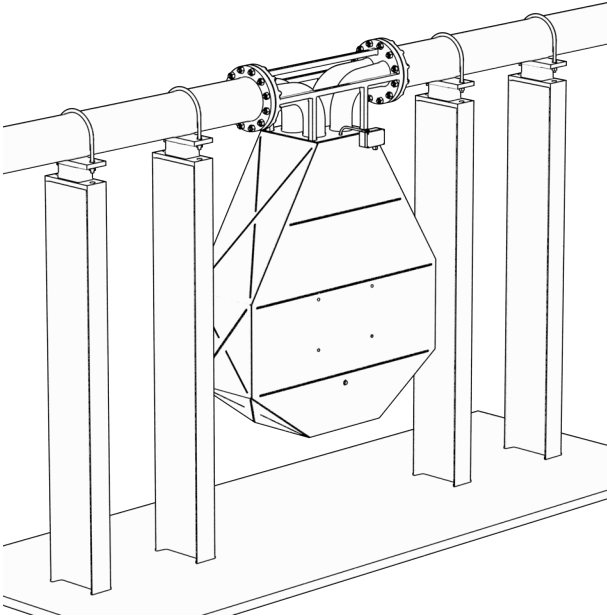

Fig. 12: Two supports on each side

Compared to one support on each side, the bending moments acting on the sensor are significantly reduced.

For maximum accuracy: Frame and vibration isolation

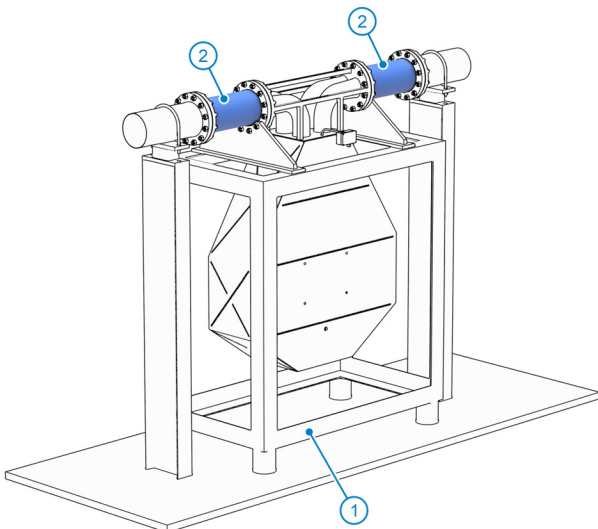

Fig. 13: Frame and compensators

A surrounding frame (1) supports the sensor. Compensators (2) isolate the sensor from system vibrations.

5.3.6 Insulation

When applying pipe insulation: Insulate the sensor along with the piping. It is important to minimize the temperature gradient between the sensor and the medium in order to achieve optimal measurement accuracy. **NOTICE!** Overheating | Do not insulate the transmitter.

5.3.7 IP protection rating

Observe the IP rating of your RHM sensor and the corresponding RHE transmitter. These are indicated on the nameplates of the sensor and transmitter. Protect the sensor and transmitter from exposure to dust and splashing water that exceeds the specified protection rating.

RHM 30 - 40

IP66, similar to Type 4/4X, optionally IP67 possible.

RHM 60 - 160

Requirement

The protection ratings listed are valid only under the following conditions:

- The openings for the transport locks in the sensor housing are sealed with the plugs provided. Refer to [5.2.2.2 Transport locks., p. 39](#).
- Cable glands and feed-throughs are properly sealed.

Depending on the permissible operating temperature, RHM sensors are available in two protection ratings. Proper thermal insulation can increase the protection rating of IP 56 / Type 3 sensors:

Permissible operating temperature	Protection rating	Protection rating with thermal insulation
Up to 120 °C	IP66, similar to Type 4/4X	IP66, similar to Type 4/4X
Above 120 °C	IP56, similar to Type 3	IP65, similar to Type 4

5.3.8 Electrical connection, grounding

⚠ CAUTION



Depending on the medium flowing through, the sensor's surfaces may be hot or cold.

Burns or frostbite

- Before performing connection work: Turn off the on-site system and wait until the sensor temperature reaches the ambient temperature.

Cable entry terminal box

Route the cables into the terminal box from below or from the side. Be sure to route the cables as perpendicularly as possible into the terminal box. No tensile stress must be applied to the cables in order to ensure that the feed through remains permanently sealed.

5.3.8.1 Cable glands in hazardous areas

Tighten the locknuts on the cable glands to the following torque. The torque must not exceed this value.

Cable gland diameter	Torque
M16	8 Nm
M20	10 Nm

5.3.8.2 Grounding

For grounding, observe the recommendations of the IEC 60079-0 standard:

- Ground shielded signal and power supply cables at one end only, at a point outside the hazardous area.

At the opposite end, you can ground the shield using a 1 nF capacitor.

- For devices with Sx connection types, use the ground terminal on the stainless steel terminal box.
- For all other connection types: Screw a grounding lug into place at the marked position (1).

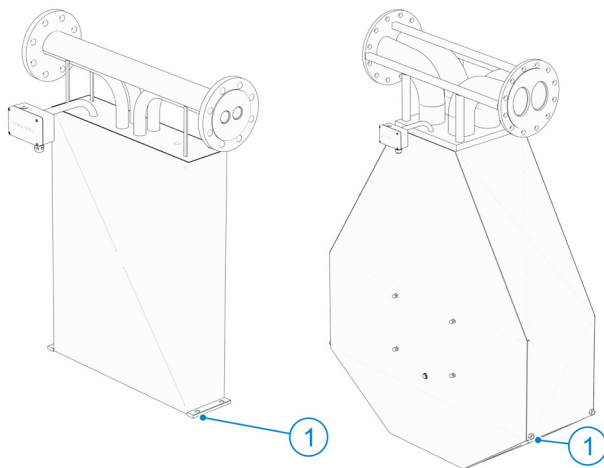

Cable length less than 10 m

For installations with cable lengths of less than 10 m, you can ground the shield at both ends.

The prerequisite is that there is no potential difference between the PE at the sensor and the PE at the transmitter. This can be assumed if there is a good metallic connection, or if a special PE cable with a cross-sectional area of at least 4 mm² connects the two grounding points.

Potential difference (PE) between sensor and transmitter

If there is a significant potential difference between the PE at the sensor and the PE at the transmitter:

- Connect the PE at the sensor to the PE at the transmitter using an equipotential bonding cable.

Shielding for Jx and Sx connection type

Terminal 10 (PE) in the terminal box is directly connected to the sensor housing.

Terminal 11 (PE_C) in the terminal box is connected to the sensor housing via a capacitor (1 nF / 1000 V).

- Connect the shield of the transmitter connection cable to one of these terminals. Observe the points mentioned above and [B Wiring diagrams, p. 81](#).
- Connect the shield of the transmitter connection cable to the transmitter. Refer to the transmitter manual.

Shielding for Tx connection type

The shield of the transmitter connection cable is connected to the sensor housing.

The standard cable length is 2 m. Therefore, the shield can normally be connected to terminal 10 (PE) of the transmitter. If this is not permitted due to local regulations, use a capacitor (1 nF/1000 V) in series.

5.3.8.3 Electrical connection

The type of electrical connection is specified in the order code. Refer to chapter [2.1 Order code](#), p. 15.

Refer to the RHE transmitter manual for further information on connecting the sensor to the RHE transmitter.

Connection types Sx, Jx, and Tx to a RHE 20

- Refer to the following wiring diagrams for connecting RHM sensors with connection types Sx, Jx, and Tx to a RHE 20 transmitter:
 - [B.1 Connection RHM Sx, Jx to RHE](#), p. 83
 - [B.2 Connection RHM TX to RHE](#), p. 85

Connection type C2: RHM with RHE 42

The RHE 42 is mounted on the top of the RHM. The connection between RHM and RHE is not accessible from the outside.

RHM and RHE must not be separated from one another.

Connection types J9 and S9: RHM with RHE 49

The RHE 49 is integrated into the terminal box. The connection between RHM and RHE is not accessible from the outside.

RHM and RHE must not be separated from one another.

Connection cable

You can use ARHE-C4 and ARHE-C6 connection cables.

property	ARHE-C4	ARHE-C6
Operating temperature	-50 °C to +105 °C	-50 °C to +105 °C
Resistance	39 Ω/km (blue, brown), 56 Ω/km (all other wires)	39 Ω/km (blue, brown), 56 Ω/km (all other wires)
Inductance	< 0.7 μH/m	< 0.7 μH/m
Wire-wire capacitance	< 90 pF/m	< 90 pF/m
Wire-shield capacitance	< 175 pF/m	< 175 pF/m
Outer diameter	9 mm	12.5 mm
Weight	1.1 kg/10 m	2.2 kg/10 m
Structure	Pair-stranded/triple-stranded	Pair-stranded/triple-stranded
Pair shield	Foil with drain wire	Foil with drain wire
Overall shield	Foil with drain wire. Shields not galvanically isolated.	Foil with drain wire. Shields not galvanically isolated.
Armor	No	Steel braid

5.4 Commissioning

For detailed information on commissioning, please refer to the RHE transmitter manual.

6 Troubleshooting

For detailed information on troubleshooting, please refer to the RHE transmitter manual.

6.1 Troubleshooting

Observation/Error description	Possible cause	Measures
RHE transmitter doesn't start	Faulty or insufficient power supply.	Check the power supply's function and specification. The power supply must provide at least 7 W for each connected RHE transmitter.
	Power supply fuse in the transmitter defective.	Replace the power supply fuse with a new Littelfuse fuse: Part number 37305000000 for DC. Part number 37202000001 for AC. Contact your local distributor or Rheonik for more information.
	The transmitter is defective.	Send the transmitter to Rheonik for repair. Replace the transmitter.
The flow is negative	Incorrect flow direction configured.	The devices are shipped with a predefined flow direction. This can be changed in the transmitter.
The device indicates a flow rate even though the inlet valve is closed and the pumps are turned off.	Leaky valve.	Clean the valve. Replace the valve.
	Convection caused by temperature differences or gradients in the pipe	Install a valve to prevent convection.
	Zero point calibration was not performed correctly.	Perform a zero point calibration.
The measured flow rate fluctuates significantly.	Strong vibrations at the sensor	Isolate the sensor from external vibrations as much as possible: Use flexible hoses to connect the sensor to the process line. Use supports with rubber dampers.

Observation/Error description	Possible cause	Measures
	Cavitation of the fluid, caused by high flow velocity and a fluid temperature close to the boiling point.	Reduce the flow rate. Increase the process pressure. Lower the process temperature. Use a larger RHM sensor.
	Pulsating flow.	Buffer the flow using rubber hoses or a buffer tank.
	two-phase mixture	Ensure that only single-phase flow is measured.
	Improper installation orientation	Check the installation orientation; refer to 5.3.2 Installation orientation, p. 42 . Ensure, through process design, that no two-phase mixture can reach the sensor, e.g., by installing a separator upstream.
	If response time is not a critical factor, the filter parameters can be applied to smooth the measured flow rate.	
The volume and density of the medium are not displayed.	Density measurement is not available or was not ordered.	Density measurement can usually be activated on-site for a service fee. Contact your local distributor or Rheonik for more information.
	Density functions disabled.	Enable a density function
The analog output does not change its value even though fluid is flowing through the sensor.	Analog output is configured incorrectly.	Check the analog output and reconfigure it if necessary.
	A negative flow rate is being measured.	If the analog output is assigned to a positive flow range, no signal is output when the flow is negative. Change the flow direction. Or assign the analog output to the negative flow range.

Observation/Error description	Possible cause	Measures
The pulse/frequency output does not change the output value even though there is flow.	Pulse/frequency output is configured incorrectly.	Check the pulse/frequency output and reconfigure it if necessary.
	A negative flow rate is being measured.	The pulse/frequency output operates only in the positive flow range. Change the flow direction. If a pulse/frequency output is required in the negative flow range, use the special settings described in the RHE20/40 Desktop Reference Manual.
The analog output is producing an incorrect value.	Analog output is configured incorrectly.	Check the analog output and reconfigure it if necessary. Check and adjust the flow unit in the transmitter
The pulse/frequency output is displaying an incorrect value.	Pulse/frequency output is configured incorrectly.	Check the pulse/frequency output and reconfigure it if necessary. Check and adjust the flow unit in the transmitter
The RHM sensor is not producing any valid signals. Bit 6 in the ErrorStatus register (0x401A) is set. Bits 12 through 14, bit 17, or bit 22 in the SoftError register (0x401C) are set. The RHE transmitter no longer reports mass flow rates and freezes the totalizers.	Short circuit broken wire	Measure the resistance between the sensor terminals and compare the results with the table. For measurement, refer to 6.2 Voltage test, resistance test, p. 67 For resistances, refer to C Terminal resistances, voltages, p. 87 Repair or replace the sensor if the readings at room temperature fall outside the specified ranges.
material failure Seal failure	Pressure higher than permitted. Vibrations	Turn off the system. Depressurize the system.

6.2 Voltage test, resistance test



Required conditions

- ✓ The sensor and transmitter are connected correctly.
- ✓ The measurement system is connected to a suitable power source and is active.



Required support equipment

- ✓ Voltmeter or multimeter.
- ✓ Ohmmeter or multimeter.



Context

Observe the permissible voltages and resistances at the sensor terminals [C Terminal resistances, voltages, p. 87](#)



Proceeding

Voltage test

1. Measure the voltage between the sensor terminals
 - The measured voltages must fall within the following ranges: [C Terminal resistances, voltages, p. 87](#)
 - The voltage difference between terminal pairs 6–7 and 8–9 must not exceed 20%.

Resistance test

2. Disconnect the sensor from the transmitter.
3. Check the internal resistances at the sensor terminals.
 - The measured resistances must fall within the following ranges: [C Terminal resistances, voltages, p. 87](#)
 - The resistance values between terminal pairs 6–7 and 8–9 must not differ by more than 20%.



Troubleshooting

If the measured voltages and resistances are outside the permissible ranges, the sensor is defective.

If only the voltages are outside the ranges (table), this indicates a fault in the transmitter.

Contact your local sales/support representative or Rheonik Support.

7 Maintenance, Inspection

Rheonik RHM sensors are generally maintenance-free and contain no user-serviceable parts. Contact your local sales/support representative or Rheonik customer support for service or repairs.

Regularly perform a visual inspection for damage to the measuring system. Determine the inspection intervals based on your specific operational conditions.

Monitor for unusual operating noises that may indicate cavitation. Refer to chapter [5.3.3.4 Cavitation, outgassing, evaporation, p. 49](#).

7.1 Zero-point calibration

Perform a zero-point calibration in the following cases:

- When a sensor or transmitter has been newly installed.
- Before performing a calibration.
- As part of a routine inspection of the sensor.

For detailed information on zero-point calibration, please refer to the RHE transmitter manual.

7.2 Options: zero-point history, check zero-point drift, assurance factor

The zero-point history and Assurance Factor options are available for transmitters in the RHE 40 Series. Refer to the manual for the corresponding RHE transmitter.

Depending on your specific requirements for measurement accuracy, you can optionally check for zero-point drift. Set the interval for this test based on the zero-point history.



Tip

The trend in zero-point drift and the assurance factor are important indicators of the sensor's condition. Sudden spikes in drift or a drop in the assurance factor indicate a technical problem or an emerging fault.

The Assurance Factor also provides a concise summary of diagnostic information regarding the reliability and performance of the measurement system in the form of a key metric. The assurance factor can have a value of 0 to 100%.

7.3 Calibration

Each Rheonik RHM sensor is shipped with factory calibration. Under normal operating conditions, regular recalibration is not necessary.

Calibration may be required, for example, due to regulatory or operational requirements. Detailed calibration instructions can be found in your RHE transmitter's manual.

7.4 Configuration file

Each sensor has its own configuration file in the corresponding transmitter. With the RHEComPro software, you can read the configuration file and save it as a CSV file. This requires installing RHEComPro and connecting the transmitter to a PC.

For direct customers, the factory settings are available as CSV files on the Rheonik Info Portal. www.rheonik.info You can transfer them to the transmitter via a PC and RHEComPro.

For more information, please refer to the RHEComPro manual.



Tip

Save the configuration file for the transmitter you are using and keep it in a safe place. This allows the original configuration to be quickly and easily restored in the event of a transmitter replacement.

8 Decommissioning, storage, recommissioning, disposal

8.1 Decommissioning, Dismantling

Before removing the sensor

- Turn off the power to the sensor.
- Disconnect the sensor from the power supply.

For extended periods of downtime

- Clean the sensor.
- Seal all openings, cable entries, and cable glands.

Cleaning the sensor is especially important in the following cases:

- When sediments can settle.
- If the medium can solidify.
- If the medium is corrosive.

8.2 Storage conditions

- Store the RHM sensor in its original packaging.

Refer to the storage instructions in Chapter [2.5.3 Environmental conditions](#), p. 23.

8.3 Restart

For detailed information on commissioning, please refer to the RHE transmitter manual.

8.4 Disposal

- Dispose of the product in accordance with local regulations.

Please contact Rheonik or your local sales representative if you need a RoHS declaration.

8.4.1 WEEE, RoHS

RHM sensors are not subject to the WEEE Directive 2012/19/EU.

RHM sensors comply with the RoHS Directive 2011/65/EU.

Appendix

A Explosion protection

If statements apply to multiple variants, they are represented by the placeholder "x".

Examples:

Jx includes JM, J2, J5, J9

Ex includes EM, E2, E3, and E4

Refer to chapter [2.1 Order code](#), p. 15.

A.1 Electrical safety limits for RHM sensors

Intrinsically safe RHM sensor

Circuit name	Clamps ¹	Ui [V]	Ii [mA]	Pi [mW]	Li [mH] ³	Ci [nF] ³
Drive circuit	1 - 2	9.3	144	335	1.5 ²	<10
Temp. Sensor	3-4, 5-4	7.4	58	107	<0.1	<10
Pickup circuit	6-7, 9-8	7.4	29	54	4,5	<10

¹ The terminal numbers are the numbers in the terminal blocks (terminal type Jx, Sx).

² With approval codes for hazardous areas "AA", "AB", "CA", or "CB": Li = 6.5 mH

³ Includes the effect of the cable for "Tx" connection types (fixed cable).

- If the RHM sensor's nameplate specifies different values, the values on the nameplate apply.
- Use only transmitters with linear barriers that have negligible Li and Ci values. All approved RHExx transmitters meet this requirement.
- The cable colors for "Tx" connection types (fixed cable) can be found in the drawings in Chapter [B.2 Connection RHM TX to RHE](#), p. 85.
- Use RHM sensors with temperature ranges "Hx" (above 210 °C) and "E3" (below -50 °C) only with certified RHE transmitters that have grounded circuits.
- Ensure equipotential bonding between the sensor and the transmitter.

RHM Sensor with type of protection ec or nA

- Connect the sensor only to Rheonik transmitters type RHE.

Sensors with connection type "J9" or "S9" are permanently connected to a RHE 49 at the factory. These connection points are not accessible from the outside.

A.2 Thermal safety limits for RHM sensors

The following sections provide information on the temperature ranges of RHM sensors.

ⓘ **Important**

Temperature ranges may be narrower than the maximum ranges specified below.

Example: The Ex temperature ranges extend from -196 °C to +210 °C. E3 is rated for temperatures ranging from -196 °C to +50 °C.

➤ Observe the information on the nameplate.

Compact versions with RHE42 or RHE49 have limited temperature ranges.

➤ Observe the information in the following sections.

You can completely insulate the RHM sensor housing as long as the terminal box remains outside the insulation.

The terminal box is designed for a temperature range of -50 °C to +105 °C.

The ARHE-C4 and ARHE-C6 connection cables are designed for a temperature range of -50 °C to +105 °C. They can be used at temperatures below -50 °C if they are installed in a rigid pipe.

RHMxxx sensors type TM are equipped with a fixed Teflon cable. The Teflon cable is designed for a temperature range of -196 °C to +205 °C.

A.2.1 Temperature ranges Nx

Temperature class	T6	T5	T4	T3	T2	T1
Min. temperature	-50 °C	-50 °C	-50 °C	-50 °C	-50 °C	-50 °C
Max. ambient temperature	65 °C	80 °C	80 °C	80 °C	80 °C	80 °C
Max. fluid temperature	65 °C	80 °C	115 °C	120 °C	120 °C	120 °C

A.2.2 Temperature ranges N1, NA with RHE 49, front mounting

Order code ranges: Mxxx - x - **Nx** - xx - xx - x - xx - xxx - **J9 or S9** -xx-xx-x-xx- x x - xx

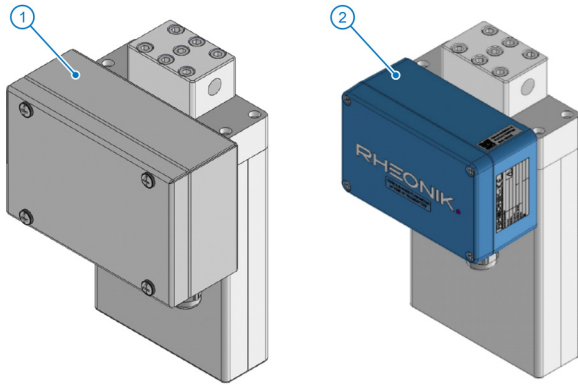
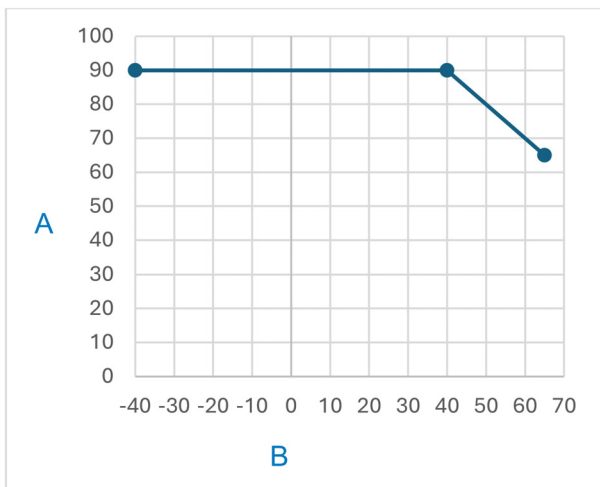

Fig. 14: Front mounting with stainless steel housing (left) or aluminum housing (right)



A Max. fluid temperature

B Ambient temperature

Minimum fluid and ambient temperature: -20 °C (N1) or -40 °C (NA)

A.2.3 Temperature ranges Ex

Temperature class	T6	T5	T4	T3	T2	T1
Min. ambient temperature	-50 °C	-50 °C	-50 °C	-50 °C	-50 °C	-50 °C
Max. ambient temperature	65 °C	80 °C	80 °C	80 °C	80 °C	80 °C
Min. fluid temperature	-196 °C*	-196 °C*	-196 °C*	-196 °C*	-196 °C*	-196 °C*
Max. fluid temperature	65 °C	80 °C	115 °C	180 °C	210 °C	210 °C

*)Applies up to a minimum ambient temperature of -40 °C. If the ambient temperature falls below -40 °C, the minimum fluid temperature increases linearly. At an ambient temperature of -50 °C, the minimum fluid temperature is -50 °C. Refer to the following diagram.

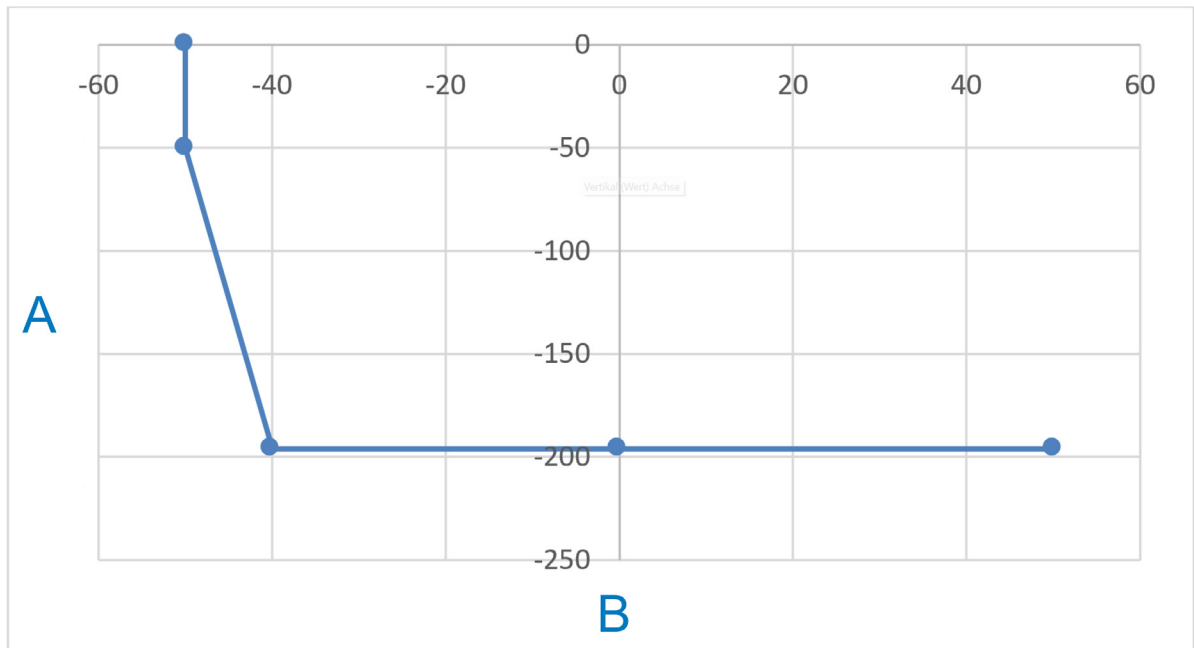
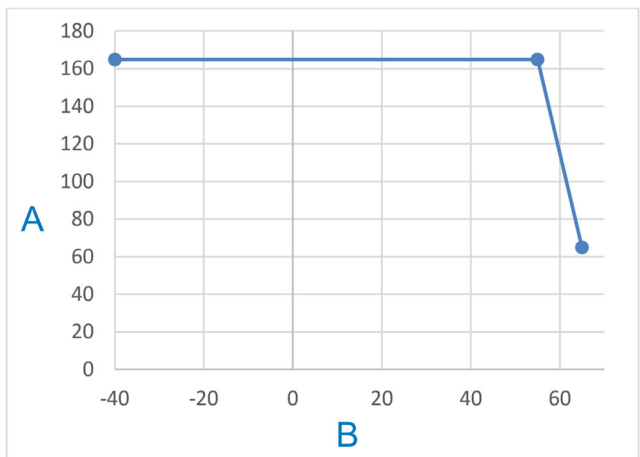

Fig. 15: Derating of the minimum fluid temperature at low ambient temperatures.

- A Min. fluid temperature
- B Ambient temperature

A.2.4 Temperature range E2 with RHE 42

Order code ranges Mxxx - x - **E2** - xx - xx - x - xx - xxx - **J2**-xx-xx-x-xx- x x - xx



- A Max. fluid temperature
- B Ambient temperature

Minimum fluid temperature and ambient temperature: -40 °C

A.2.5 Temperature range E2 with RHE 49, set-off mounting

Order code ranges Mxxx - x - **E2** - xx - xx - x - xx - xxx - **J9 or S9**-xx-xx-x-xx- x x - xx

Note: The illustration shows the version with aluminum housing (J9). The diagram also applies to stainless steel housings (S9).

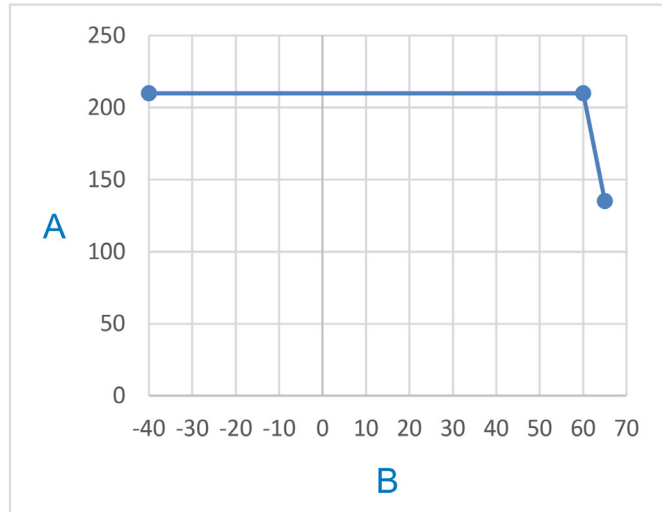
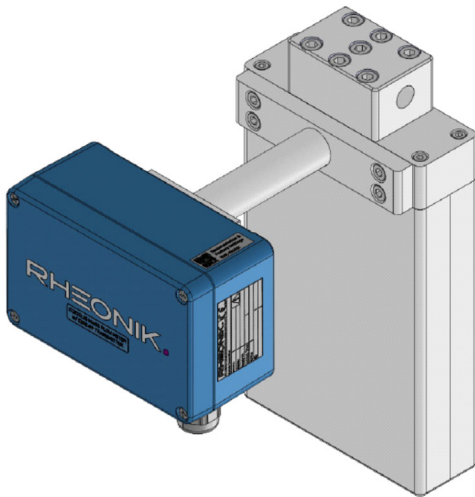

A Max. fluid temperature

B Ambient temperature

Minimum fluid and ambient temperature: -40 °C

A.2.6 Temperature ranges N1, NA, and E2 with RHE 49, top mounting

Order code ranges Mxxx - x - **E2 / N1 / NA** - xx - xx - x - xx - xxx - **J9 or S9**-xx-xx-x-xx- x x - xx

Note: The illustration shows the version with aluminum housing (J9). The diagram also applies to stainless steel housings (S9).

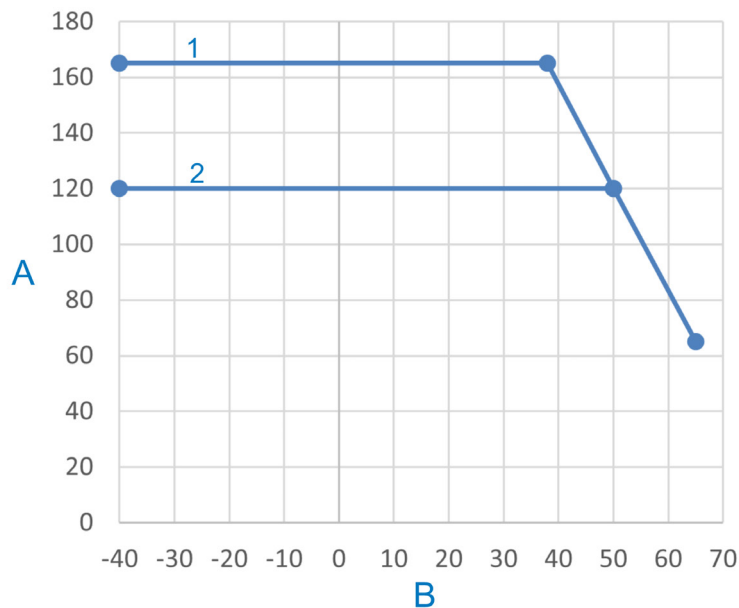
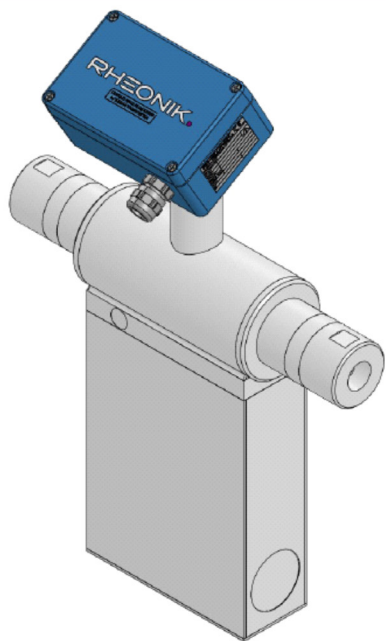

- A Max. fluid temperature
- B Ambient temperature
- 1 Temperature ranges Ex
- 2 Temperature ranges Nx

Minimum fluid and ambient temperature: -20 °C (N1) or -40 °C (NA, E2)

A.2.7 Temperature ranges Hx

The optimal operating temperature is between 100 °C and 400 °C. For continuous operating temperatures below 100 °C, Rheonik recommends using sensors with an N* or E* temperature range.

Temperature class	T6	T5	T4	T3	T2	T1
Min. temperature	-	-	-20 °C	-20 °C	-20 °C	-20 °C
Max. ambient temperature	-	-	80 °C	80 °C	80 °C	80 °C
Max. fluid temperature	-	-	105 °C	170 °C	270 °C	400 °C

B Wiring diagrams

B.1 Connection RHM Sx, Jx to RHE

Safe Area or Zone 2 or Zone 1 / Div. 2 or Div. 1

(depending on type and certification of RHE 20/40)

Hazardous Area

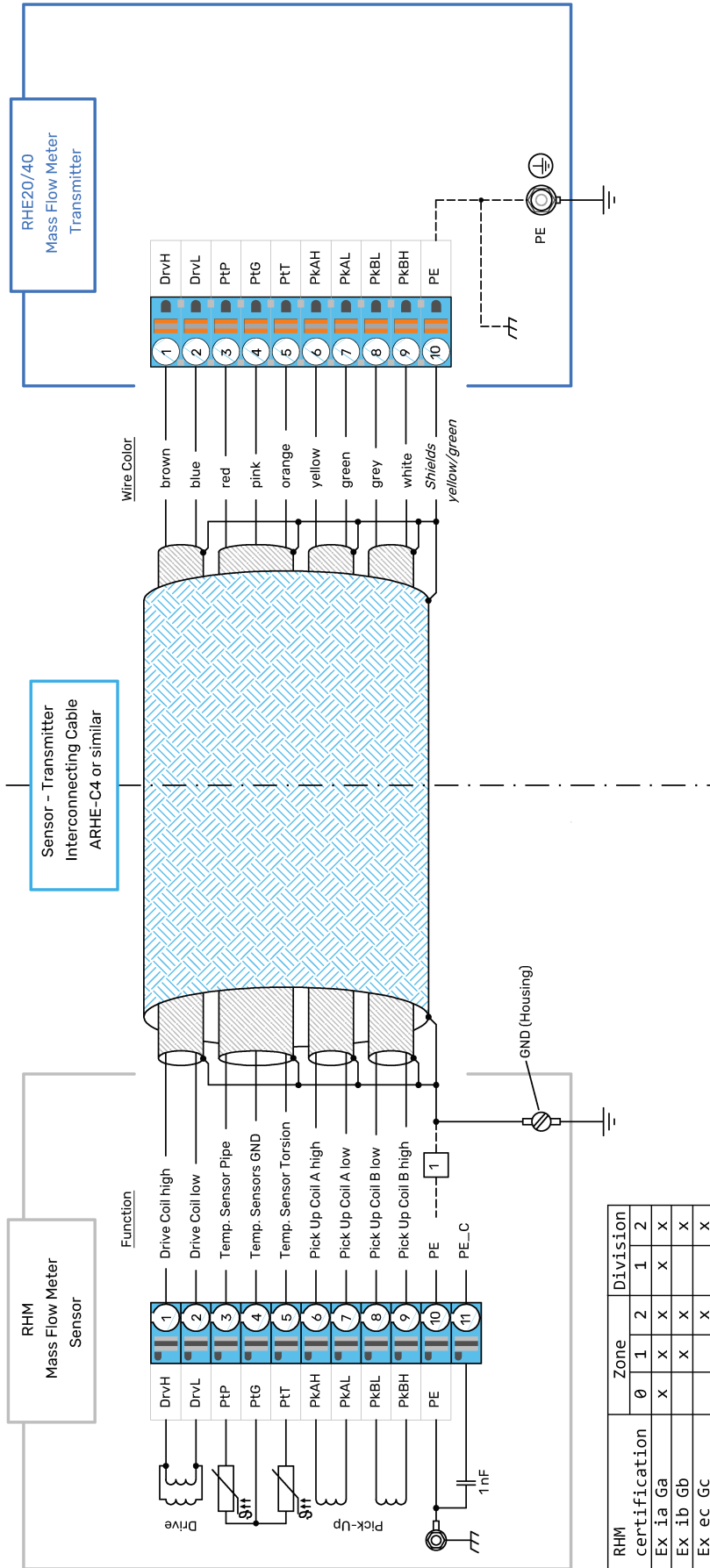

B.2 Connection RHM TX to RHE

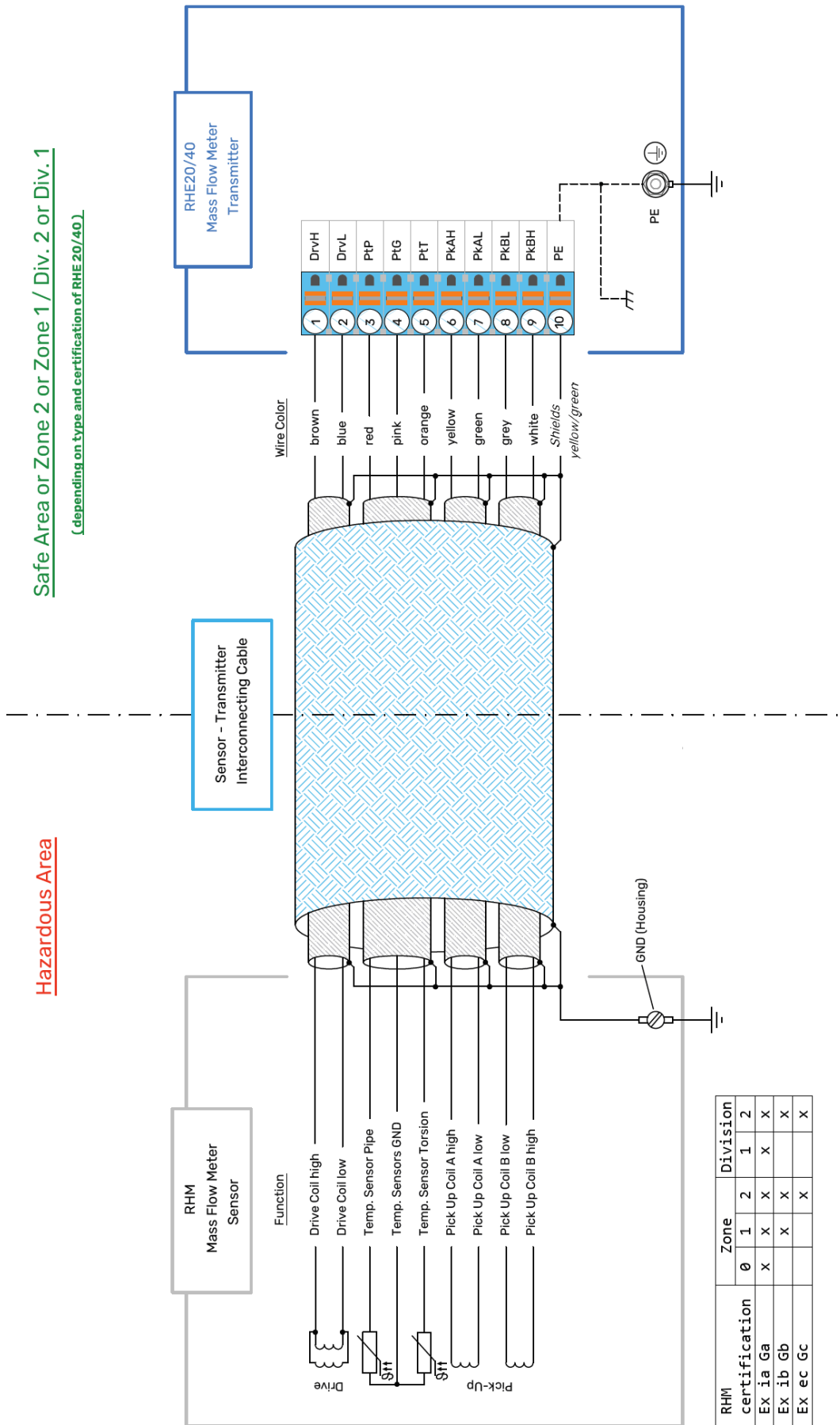

C Terminal resistances, voltages

All values are valid at 20 °C

Terminal blocks Sensor	Resistance	
	Temperature range H4	All other Temperature ranges
<i>RHM 30</i>		
1 – 2	10–31 Ω	37–50 Ω
3 – 4	approx. 108 Ω ¹ / 1078 Ω ²	approx. 108 Ω ¹ / 1078 Ω ²
4 – 5	approx. 108 Ω ¹ / 1078 Ω ²	approx. 108 Ω ¹ / 1078 Ω ²
6 – 7	115 - 143 Ω	9–17 Ω
8 – 9	115 - 143 Ω	9–17 Ω
1...9 – Housing	> 10 MΩ – ∞	> 10 MΩ – ∞
<i>RHM40</i>		
1 – 2	38–48 Ω	25–62 Ω
3 – 4	approx. 108 Ω ¹ / 1078 Ω ²	approx. 108 Ω ¹ / 1078 Ω ²
4 – 5	approx. 108 Ω ¹ / 1078 Ω ²	approx. 108 Ω ¹ / 1078 Ω ²
6 – 7	115 - 145 Ω	55–68 Ω
8 – 9	115 - 145 Ω	55–68 Ω
1...9 – Housing	> 10 MΩ – ∞	> 10 MΩ – ∞
<i>RHM 60</i>		
1 – 2	21–31 Ω	23–64 Ω
3 – 4	approx. 108 Ω ¹ / 1078 Ω ²	approx. 108 Ω ¹ / 1078 Ω ²
4 – 5	approx. 108 Ω ¹ / 1078 Ω ²	approx. 108 Ω ¹ / 1078 Ω ²
6 – 7	121–141 Ω	56 - 72 Ω
8 – 9	121–141 Ω	56 - 72 Ω
1...9 – Housing	> 10 MΩ – ∞	> 10 MΩ – ∞
<i>RHM 80</i>		
1 – 2	22–35 Ω	14–26 Ω
3 – 4	approx. 108 Ω ¹ / 1078 Ω ²	approx. 108 Ω ¹ / 1078 Ω ²
4 – 5	approx. 108 Ω ¹ / 1078 Ω ²	approx. 108 Ω ¹ / 1078 Ω ²
6 – 7	110–140 Ω	55 - 72 Ω
8 – 9	110–140 Ω	55 - 72 Ω
1...9 – Housing	> 10 MΩ – ∞	> 10 MΩ – ∞
<i>RHM 100</i>		

Terminal blocks Sensor	Resistance	
1 – 2	N/A	14–25 Ω
3 – 4	N/A	approx. 108 Ω ¹ / 1078 Ω ²
4 – 5	N/A	approx. 108 Ω ¹ / 1078 Ω ²
6 – 7	N/A	57–72 Ω
8 – 9	N/A	57–72 Ω
1...9 – Housing	N/A	> 10 MΩ – ∞
<i>RHM 160</i>		
1 – 2	N/A	14–25 Ω
3 – 4	N/A	approx. 108 Ω ¹ / 1078 Ω ²
4 – 5	N/A	approx. 108 Ω ¹ / 1078 Ω ²
6 – 7	N/A	23–36 Ω
8 – 9	N/A	23–36 Ω
1...9 – Housing	N/A	> 10 MΩ – ∞

¹ Pt100 temperature sensor

² Pt1000 temperature sensor

Terminal blocks Sensor	Tension
1 – 2	0.25–5 V AC
6 – 7	10 – 150 mV AC
8 – 9	10 – 150 mV AC

List of Figures

Fig. 1:	Sensor design: exterior view with housing. Schematic diagram; model-specific design is similar.....	33
Fig. 2:	Lifting eyes on sensor housings.....	37
Fig. 3:	Lifting using tubes.....	38
Fig. 4:	Transport locks.....	39
Fig. 5:	Connection flanges parallel and square.....	43
Fig. 6:	Two-phase mixture: liquid/solid (left), liquid/gaseous (center).....	44
Fig. 7:	Shut-off valves for zero-point calibration.....	45
Fig. 8:	Downpipe.....	48
Fig. 9:	Sensor installation position downstream of a pump.....	49
Fig. 10:	Out of plane installation orientation. Sensor shown without housing; fluid flow direction shown in blue.....	50
Fig. 11:	Supports.....	52
Fig. 12:	Two supports on each side.....	53
Fig. 13:	Frame and compensators.....	53
Fig. 14:	Front mounting with stainless steel housing (left) or aluminum housing (right).....	77
Fig. 15:	Derating of the minimum fluid temperature at low ambient temperatures.....	78

About Rheonik

Rheonik has but one single purpose: to design and manufacture the very best Coriolis meters available.

Our research and engineering resources are dedicated to finding new and better ways to provide cost effective accurate mass flow solutions that provide value to our customers. Our manufacturing group care for each and every meter we produce from raw materials all the way to shipping, and our service and support group are available to help you specify, integrate, start-up and maintain every Rheonik meter you have in service. Whether you own just one meter or have hundreds, you will never be just another customer to us. You are our valued business partner.

Need a specific configuration for your plant? Don't compromise with a "standard" product from elsewhere that will add extra cost to your installation. If we can't configure it from our extensive and versatile product range, our exclusive **AnyPipeFit Commitment** can have your flow sensor customized with any size/type of process connection and face to face dimension you need.

No matter what control system you use as the backbone in your enterprise, with our **AnyInterface Commitment**, you can be sure that connection and communication will not be a problem. Alongside a wide variety of discrete analog and digital signal connections, we can also provide just about any network/bus interface available (for example: HART, ProfibusDP, ProfiNet, EtherCAT, PowerLink, EtherNet/IP, CAN, ...) with our RHE 40 Series family of transmitters. Rheonik RHE 40 Series transmitters can connect to your system – no headache and no conversion needed.

Rheonik Messtechnik GmbH
Rudolf-Diesel-Str. 5
85235 Odelzhausen
Germany

info@rheonik.com

