

RHM 015

Coriolis Mass Flow Meter for Accurate Flow Measurement in Process Applications

Features

- Typical measuring range up to 0.6 kg/min
- Pressure ratings up to 1379 bar (20000 psi)
- Temperature ratings from -50 to +210 °C (-58 to +410 °F) – extended on request
- Mass flow uncertainty down to 0.05 %
- Repeatability down to 0.05 %
- 4 kHz measurement updates and response time of less than 1 ms when used with 40 Series transmitters
- Accurately measures flow rates down to 4 g/min
- Rheonik **AnyPipeFit Commitment** brings you the possibility to get any custom process connection type and size for savings on installation costs. Compact design with minimal footprint
- Approved for use in hazardous areas
- Stainless steel case
- Integral or remote transmitter versions available

Applications

- General Flow Control
- Additive Dosing
- Mixing and Batching
- Chemical Injection
- Package and Container Filling

Rheonik Sensor Benefits

- Torsion oscillator design assures a stable and drift free measurement with excellent signal to noise ratios
- Resilient to external noise and vibration
- Insensitive to pipe pressure changes
- Robust tube wall thickness provides increased operational safety in abrasive applications
- Long life guaranteed due to low mechanical stresses in the sensor mechanism
- No moving parts to wear or fail

General Specification Overview

Nominal Flow (Q_{nom})*	0.6 kg/min (1.32 lb/min)
Maximum flow rate (Q_{max})*	1.2 kg/min (2.65 lb/min)
Typical Minimum flow (Q_{min})*	0.004 kg/min (0.009 lb/min)
Serial Tube / Single Path	Flow rates will be 50 % of the above listed parallel / dual path version
Operating Temperature	Fluid temperature range options cover from -50 °C to +210 °C (-58 °F to +410 °F) For integral transmitter versions please refer to transmitter datasheet
Humidity Limits	5 to 95 % relative humidity, non-condensing at +60 °C (+140 °F)
Ambient Temperature	-50 °C to +80 °C (-60 °F to +180 °F) (standard), version available for installation in oven (up to +210 °C/+410 °F) (optional)
Pressure Ratings	Up to 1379 bar/20000 psi – dependent upon material
Electrical Connection Sensor w/o integral Transmitter	Cable entry M25 x 1.5 (standard), M20 x 1.5, ½" NPT, ¾" NPT (optional) Max. cable length to remote RHE transmitter 100m / 330ft
Sensor Enclosure Materials	Stainless steel 304 (standard), 316 (optional) Coated aluminum terminal box (standard), 316 terminal box (optional)
Enclosure Type	Protection class IP 66 / NEMA 4 (standard), IP 66/67 / NEMA 4X (optional)
Wetted Materials	Flow tubes 316L, SuperDuplex or Alloy C22, manifolds 316L, seals FKM or FFKM or FVMQ Standard flanges 316Ti, other connections 316 Additional/customer specific materials available upon request
Process Connections	Nearly any - the RHEONIK AnyPipeFit Commitment . Consult factory for types/sizes not listed in this data sheet on the Mechanical Construction pages
Pressure Rating Compliance	PED according to Sound Engineering Practice (SEP)
Certifications and Approvals	ATEX / IECEx Approvals zone 0, 1 (suitably rated RHE transmitter required), zone 2 North American Approvals Class I, Div. 1, Groups ABCD (suitably rated RHE required) NMI MID custody transfer approval American Bureau of Shipping (ABS) Product Type Approval for use on marine vessels
Testing and Inspection	All sensors are hydro tested, calibrated and supplied with a traceable calibration certificate. Customized calibration and testing services are available
Project Documentation and QA, Services	Rheonik offers a full set of services for large and complex engineering projects. Typical services offered are, but not limited to: <ul style="list-style-type: none"> • Certificates of origin and conformity, mill certificates • Data books including WPAR, WQS, NDT, test & quality plans, functional testing, calibration procedures, customized packing, factory acceptance etc. • Painting to project specification • Start up and commissioning services on/offshore
Options	Special customized solution for machine integration Heating systems, Cleaning for oxygen service, ... For more - consult factory

* At Q_{nom} pressure drop across a parallel tube sensor will be approximately 2 bar (29 psi) for H₂O. Sensors can be operated at higher flow rates up to Q_{max} but pressure drop will be higher. Typical Minimum Flow Q_{min} is the recommended lowest flow rate for accurate measurement. Sensors will measure flow rates lower than Q_{min} but uncertainty will increase beyond 1 % of rate.

The flow rate specifications above relate to standard pressure, parallel tube, manifold sensor versions. Models with higher pressure ratings have increased wall thickness and will have higher pressure drops.

Measurement Performance

Standard and Premium Calibration

A	0.20% Uncertainty <i>Requires RHE16 or higher transmitter. All others 0.5%</i>
B	0.15% Uncertainty <i>Requires 20 Series transmitter or higher</i>

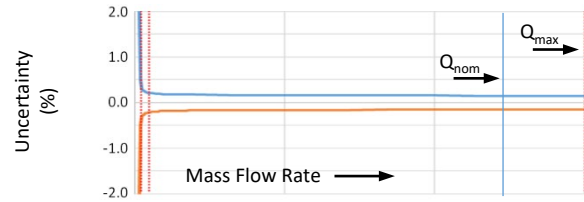

Premium Plus and Ultimate Calibration

G	0.10% Uncertainty <i>Requires 20 Series transmitter or higher</i>
U	0.05% Uncertainty <i>Requires 40 Series transmitter or higher</i>

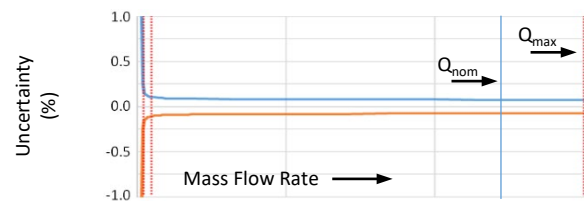

Low Flow and Customized Calibration

1	0.1% Low Flow Focused Calibration* <i>Requires 40 Series transmitter or higher</i>
X	Customized Calibration** <i>Consult factory</i>

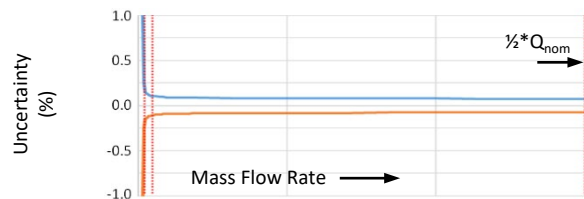

Density Calibration / Performance (Liquid)

N	No Density Calibration
S	Standard 0.0035 kg/liter Uncertainty
D	Enhanced 0.0005 kg/liter Uncertainty

Flow Measurement Repeatability

Standard Sensors $\pm 0.1\%$ of rate
Gold Line Sensors $\pm 0.05\%$ of rate

Temperature Performance

Better than $\pm 1^\circ\text{C}$

Premium Plus, Ultimate, Low Flow and Enhanced Density Calibration come with Gold Line sensors and are not available in all materials, pressure and temperature ranges.

* Low flow calibration focuses on the range from 50% Q_{nom} down to typical min. rate Q_{min} . Often used for low pressure gas or very viscous liquids

** Customized calibration uses specific calibration points according to customer requirements

Uncertainties and flow measurement turn-down

All uncertainty statements refer to reference conditions – mass flow of water, 18–24 °C, 1–3 bar in a standard temperature, pressure and material configuration sensor. The sensor can be used to measure gas – uncertainty values for gas equal the liquid value plus 0.3%. Reference conditions for gas are mass flow of natural gas, 18–24 °C, 35 to 100 bar in a standard temperature, pressure and material configuration sensor.

The turn down capability from Q_{nom} of the flow sensor is mainly driven by its zero point stability. At the very low end of the measuring range the uncertainty (u) is dominated by the zero point stability. The zero point stability of a standard sensor is: 0.000036 kg/min (0.000079 lbs/min). Zero stability of a Gold Line sensor is 0.000019 kg/min (0.000042 lbs/min).

For flow $Q \geq$ zero stability / (calibration uncertainty/100) $\rightarrow u =$ calibration uncertainty

For flow $Q <$ zero stability / (calibration uncertainty/100) $\rightarrow u =$ (zero stability/ Q) * 100

Uncertainties from environmental and process conditions

If sensors are not zeroed at operating conditions, minor additional uncertainties can arise from elevated pressures and temperatures

- Process temperature effect on mass flow: additional uncertainty of $\pm 0.0014\%$ of maximum flow per °C
- Process temperature effect on density: additional uncertainty of $\pm 0.000641 \text{ g/cm}^3$ per °C difference from calibration temperature with standard density calibration and of $\pm 0.000073 \text{ g/cm}^3$ per °C difference from calibration temperature with enhanced density calibration. This effect can be mitigated by a simple field density adjustment at operating conditions
- Process pressure on flow: The effect of pressure on flow measurement is 0.0001 % of rate per bar. Compensation is possible by pressure sensor input (analog input or digital write) or manual value entry into the transmitter
- Process pressure on density: The effect of pressure on density measurement is 0.00002 g/cc per bar. Compensation is possible by pressure sensor input (analog input or digital write) or manual value entry into the transmitter

Pressure Drop

Every Coriolis flow sensor generates pressure drop across its inlet and outlet when in use. The amount of pressure drop generated is mainly a function of the flow velocity within its tubes and the flowing viscosity of the stream. Larger flow sensors tend to generate less pressure drop than smaller flow sensors for the same velocity.

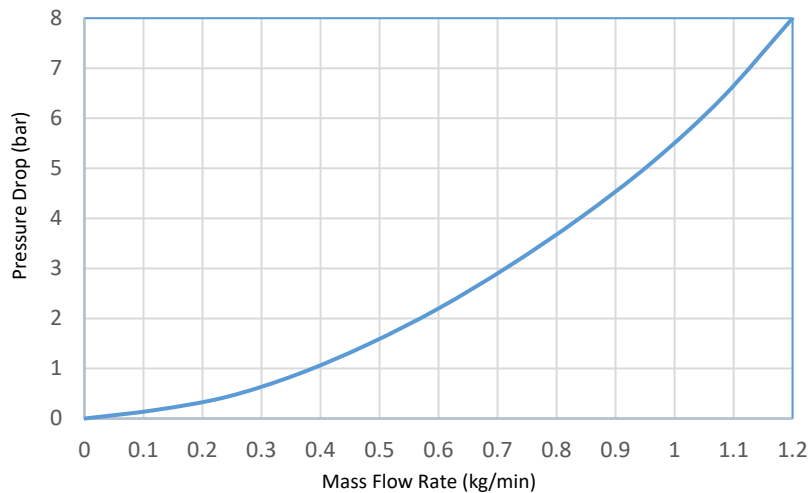

0 – 1.2 kg/min water, sensor with P1 pressure rating. Higher viscosities create higher pressure drop

Measurement Tube Pressure Ratings

The maximum pressure (P_{max}) of a sensor is determined by its lowest rated part. The lowest rated part can be either the measurement tube (P_{max} indicated below), the connection block/manifold (P_{max} indicated in the Part Number Code section) or the process connection (for P_{max} see published standards or manufacturer information).

	P1 - 316L (standard)		P1 - Alloy C22		P2 - SuperDuplex*		P3 - SuperDuplex*		P4 - SuperDuplex*	
	bar	psi	bar	psi	bar	psi	bar	psi	bar	psi
50 °C / 122 °F	450	6527	450	6527	630	9137	1050	15229	1379	20001
120 °C / 248 °F	400	5802	400	5802	540	7832	900	13053	1220	17695
210 °C / 410 °F	330	4786	330	4786	410	5947	720	10443	1150	16679

* Note minimum operating temperature for SuperDuplex stainless steel is -40 °C

Other Materials

Other wetted materials may be possible for chemical compatibility, lower pressure drop, abrasion allowance, other application specific requirements. Rheonik can provide nearly any material for the wetted parts.

Contact factory with specification for assessment and availability.

Mechanical Construction

Sensors are manufactured with two internal measurement tubes arranged side by side. In parallel or dual path sensors (order code Pxx), these tubes are connected in parallel and the flowing fluid is split equally between them. In serial or single path sensors (order code Sxx), the internal tubes are connected end to end, creating a single path through which all fluid flows. Manifold designs have a removable inlet/outlet manifold block and utilize selectable seals between the manifold and sensor body. Seal-less designs do not have seals. Manifold designs offer shorter delivery lead times and may have a lower pressure drop than seal-less designs for the same flow rate.

Manifold design with thread connections

PM0/PH0: parallel tube / dual path

SM0/SH0: serial tube / single path

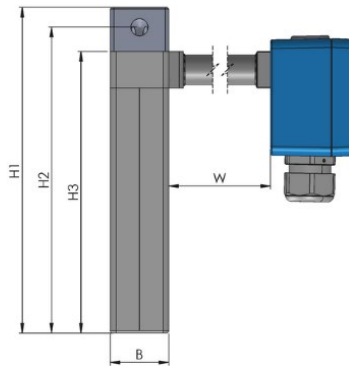
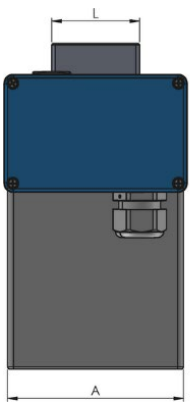

C Process Connection PM0 / SM0 / PH0	Dim. L	Order Code
	mm / in	
Female Thread G 1/2" - PM0	60 / 2.36	G1
Female Thread 1/2" NPT- PM0	60 / 2.36	N1
Autoclave 3/8" MP - 9/16" - 18 UNF Female Thread - only PH0	70 / 2.76	P2

Common Dimensions for all Construction Types:

- Standard blue aluminum terminal box, size = 125 x 80 x 57 mm (4.92 x 3.15 x 2.24 in)
- Terminal boxes are supplied with an M25 x 1.5 cable entry and a polyamide compression cable gland fitting (for cable diameters 7 - 14 mm / 0.28 - 0.56 in). M20 x 1.5, 1/2" NPT, 3/4" NPT cable entries (**without gland**) are optionally available and must be ordered separately

Optionally available (see Part Number Code):

- SS 316 box, size = 100 x 100 x 61 mm (3.94 x 3.94 x 2.40 in) – only with remote transmitter

Integral Transmitter Options:

- RHE45 transmitter in blue aluminum box. Dimensions as standard blue aluminum terminal box - see RHE45 datasheet for additional details. Manifold versions with RHE45 are available with Temperature N1, NA, E2; sealless versions only with N1, NA

Weights and Shipping Dimensions:

- Approx. weight for manifold construction sensor with threads: 2.9 kg / 6.4 lb
- Approx. weight for seal-less construction sensor with 1/2" 150# flanges: 3.8 kg / 8.4 lb
- Shipping carton size approx. 60 x 41 x 32 cm (24 x 16 x 13 in)
- Gross weight of seal-less construction meter with 1/2" 150# flanges and RHE28 transmitter approx. 11 kg / 24 lb

Common Dimensions	mm	in
A	120	4.72
B	40	1.57
H1 (PM0, PH0)	222	8.74
H1 (SM0, SH0)	267	10.51
H1 (PF0, PFT)	239	9.41
H2	208	8.19
H3	192	7.56
W (Temp. N1, NA with JM, J5 Box)	2	0.08
W (Temp. N1, NA with SM Box)	30	1.18
W (Temp. E2, E3, H4)	100	3.94

Mechanical Construction (continued)

Seal-less design with flange/hub connections

PFO: parallel/dual path

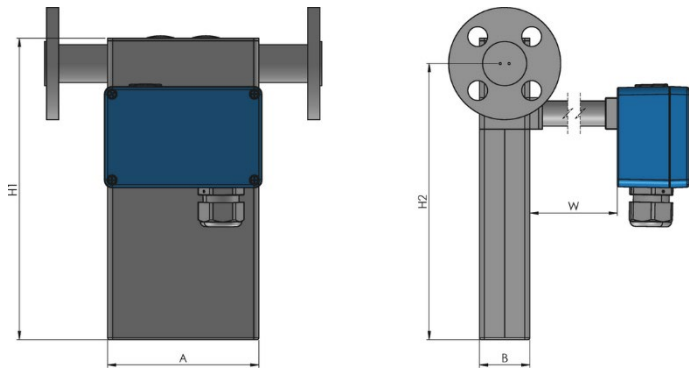

Meter will be supplied with a wetted material facing disc and 1.4571 (316Ti) stainless steel backing flange for some material selections (e.g. Alloy C22)

Process Connection	Dim. L		Order Code
	mm / in		
Flange ANSI ½" 150#RF	220		A1
Flange ANSI ½" 300#RF	220		A2
Flange ANSI ½" 600#RF	220		A3
Flange ANSI ½" 1500#RF	300		A6
Flange ANSI ½" 1500#RTJ	300		R1
Flange ANSI ½" 2500#RF	300		A8
Flange DIN DN15/PN40	220		D1
Flange DIN DN15/PN100	220		D2
Flange DIN DN15/PN160	220		D3
Grayloc® Hub 1" GR4	300		H1

1. For other hub connections (e.g. Destec, Galperti, Techlok) please consult factory

Seal-less design with threaded connections

PFT: parallel/dual path

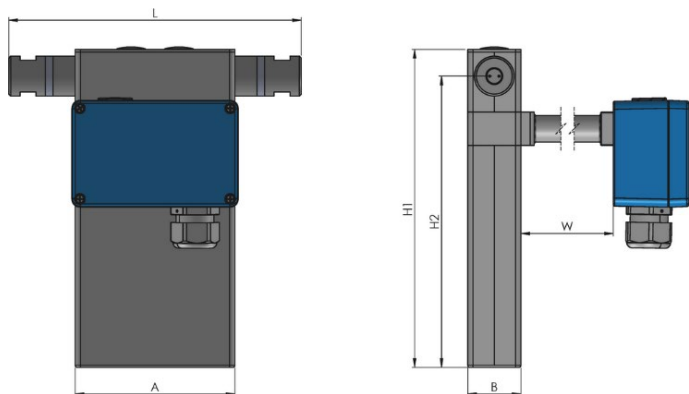

Process Connection	Dim. L		Order Code
	mm / in		
Female Thread G 1/4"	220 / 8.66		G1
Female Thread 1/4" NPT	220 / 8.66		N1
Swagelok® 1/4" Tube Inlet male (SS-400-1-4W)	220 / 8.66		W1
Swagelok® 1/4" O-Ring Connection male (SS-4-VCO-1)	consult factory		V1
Swagelok® 1/4" O-Ring Connection female (SS-4-VCO-3 and -4)	consult factory		V2
Swagelok® 1/4" with Metal Gasket female (SS-4-VCR-1 and -3)	consult factory		V3
Autoclave 3/8" MP - 9/16" - 18 UNF Female Thread	220 / 8.66		P1

All dimensions are for standard products. For customization of face to face length and/or process connection types other than the ones listed on this page, please consult factory. Note that larger diameter flange process connections are always possible.

Material of Manifold Seals (Wetted Part)

Depending upon sensor temperature range, sensors are supplied with the following seal types as standard

Temperature Range	PM0/SM0	PH0/SH0
N1	FKM	FKM
NA	FVMQ	FVMQ
E2	FFKM	n/a

For alternative seal options (e.g. FVMQ seals for N1) and seals for better chemical compatibility, please see Options or contact factory.

Options and Accessories

Part Number Option Codes	
N7	Upgrade to dual rating IP66/IP67
FO	FVMQ Seals for connection manifolds instead of Standard Seals
FK	FFKM Seals for connection manifolds instead of Standard Seals
PD	Purge with Rupture Disc
DY	Dye penetrant weld inspection
XR	X-ray weld test - only for Type _FO with flange
TP	Stainless steel tag plate
F	Removal of rest water from calibration with compressed air
O	Special Cleaning, water and fat free

Cable Entry Options (order separately)	
ORHM-E1	½" NPT Terminal Box Cable Entry
ORHM-E2	M20 x 1.5 Terminal Box Cable Entry
ORHM-E3	¾" NPT Terminal Box Cable Entry

Standard cable entry on terminal box is M25 x 1.5

Transmitter Range



Any Rheonik Mass Flow Transmitter model can be combined with any Rheonik Mass Flow Sensor to provide an overall mass flow measurement system to suit any requirement. Rheonik Coriolis transmitters are available in versions specifically designed for process, industrial and OEM applications. Economical blind front versions of some transmitters are available where displays and keypads are not required. The wide range of sensors and transmitters provide tremendous options for system designers and end users alike.

About Rheonik

Rheonik has but one single purpose: to design and manufacture the very best Coriolis meters available. Our research and engineering resources are dedicated to finding new and better ways to provide cost effective accurate mass flow solutions that provide value to our customers. Our manufacturing group care for each and every meter we produce from raw materials all the way to shipping, and our service and support group are available to help you specify, integrate, start-up and maintain every Rheonik meter you have in service. Whether you own just one meter or have hundreds, you will never be just another customer to us. You are our valued business partner.

Need a specific configuration for your plant? Don't compromise with a "standard" product from elsewhere that will add extra cost to your installation. If we can't configure it from our extensive and versatile product range, our exclusive **AnyPipeFit Commitment** can have your flow sensor customized with any size/type of process connection and face to face dimension you need.

No matter what control system you use as the backbone in your enterprise, with our **AnyInterface Commitment**, you can be sure that connection and communication will not be a problem. Alongside a wide variety of discrete analog and digital signal connections, we can also provide just about any network/bus interface available (for example: HART, ProfibusDP, ProfiNet, EtherCAT, PowerLink, EtherNet/IP, CAN,) with our 40 Series family of transmitters. Rheonik 40 Series transmitters can connect to your system – no headache and no conversion needed.